



HotSpring[®]
Portable Spas

**OWNER'S
MANUAL**

**Watkins
Manufacturing
Corporation**



HotSpring[®]
Portable Spas

OWNER'S MANUAL

This Owner's Manual has been expressly designed to acquaint you with your new spa's operation and general maintenance. We suggest that you take some time to carefully review all seven sections. Please keep this manual available for reference.

If you have any questions about any aspect of your spa's set-up, operation or maintenance, contact your authorized HOT SPRING Spa dealership. They are trained professionals who are familiar with the product as well as with new spa ownership concerns. Their expertise will facilitate the enjoyment of your new HOT SPRING Spa.

The Serial
Number/Identification label
is located within the
equipment compartment
of your HOT SPRING SPA.

IMPORTANT: Watkins
Manufacturing Corporation
reserves the right to
change specifications or
design without notification
and without incurring
any obligation.

DATE PURCHASED: _____

DATE INSTALLED: _____

DEALER: _____

ADDRESS: _____

TELEPHONE: _____

SPA MODEL/SERIAL NUMBER: _____

COVER SERIAL NUMBER: _____

IMPORTANT!

In **most** cities and counties, permits will be required for the installation of electrical circuits or the construction of exterior structures (decks and gazebos). In addition, some communities have adopted residential barrier codes which may require fencing and/or self-closing gates on the property to prevent unsupervised access to a pool (or spa) by children under 5 years of age. Your HOT SPRING Portable Spa is equipped with a locking thermal cover that meets the ASTM F1346-91 Standard for Safety Covers and as a result, is usually exempt from most barrier requirements. As a general practice, your local Building Department will inform you of any applicable barrier requirements at the time a permit is obtained for the installation of an electrical circuit. Your HOT SPRING Spa dealer can provide information on which permits may be required.

The following instructions are required to be printed by Underwriters Laboratories as a condition of their listing of this product. They contain important safety information, and we strongly encourage you to read and apply them.

IMPORTANT SAFETY INSTRUCTIONS

WHEN INSTALLING AND USING THIS ELECTRICAL EQUIPMENT, BASIC SAFETY PRECAUTIONS SHOULD ALWAYS BE FOLLOWED, INCLUDING THE FOLLOWING:

1. **READ AND FOLLOW ALL INSTRUCTIONS**
2. **WARNING**—To reduce the risk of injury, do not permit children to use this product unless they are closely supervised at all times.
- 2A. **DANGER—RISK OF CHILD DROWNING.** Extreme caution must be exercised to prevent unauthorized access by children. To avoid accidents, ensure that children cannot use the spa or hot tub unless they are supervised at all times.

115 Volt, cord and plug connected – Models F, H, I, J

- 3A. **DANGER—RISK OF INJURY.** Connect only to a grounded, grounding type receptacle.
- B. Do not bury the power cord.
- C. **WARNING**—To reduce the risk of electric shock, replace a damaged cord immediately.
4. A ground terminal (pressure wire connector) is provided on the surface of the control box inside the equipment compartment. This connector should be bonded with a minimum No. 8 AWG (8.4mm²) solid copper wire between this unit and any metal ladders, metal water pipes, metal enclosures of electrical equipment, conduit or metal equipment within 5 feet (1.52m) of the spa

to comply with local requirements. If the spa is located on a reinforced concrete pad, the reinforcing steel should also be bonded to the ground terminal.

5. **WARNING**—Your spa is equipped with a ground fault circuit interrupter (G.F.C.I.) on the end of the power supply cord. Before each use of the spa, with the plug connected to the power supply and the unit operating, push the “Test” button. The unit should stop operating and the G.F.C.I. L.E.D. indicator will go out. Wait 30 seconds and then reset the G.F.C.I. by pushing the “Reset” button. The spa should now operate normally. Failure to wait 30 seconds before resetting the G.F.C.I. may cause the spa’s Power On LED to blink. If this occurs repeat the G.F.C.I. test procedure. If the interrupter does not perform in this manner, a ground current is flowing indicating the possibility of an electric shock. Disconnect the plug from the receptacle until the fault has been identified and corrected.

230 Volt, permanently installed models with G.F.C.I.—Models G, K, FH, IH

6. A green colored terminal marked “G” is provided in the wiring box located inside the equipment compartment. To reduce the risk of electric shock, connect this terminal or connector to the grounding terminal of your electric service or supply panel with a continuous green, insulated copper wire. This wire must be equivalent in size to the circuit conductors supplying the equipment. In addition, a second wire connector is provided for bonding to local ground points. To reduce the risk of electric shock, this connector should be bonded with a No. 8 AWG (8.4mm²) solid copper wire to any metal ladders, water pipes, or other metal within 5 feet (1.52m) of the spa to comply with local requirements.
7. Your spa comes with ground fault circuit interrupter breakers in the subpanel

provided with the unit. Before each use of the spa and with the unit operating, push the "Test" button on each breaker. The switch should click over to the "Trip" position. Wait 30 seconds and reset each G.F.C.I. breaker by switching it completely off and then completely on. The switch should then stay on. If any of the interrupters do not perform in this manner, a ground current is flowing indicating the possibility of an electric shock. Disconnect the power until the fault has been identified and corrected.

8. Install the spa so proper drainage is provided for the compartment containing the electrical components.
9. DANGER—RISK OF ELECTRIC SHOCK. Install the spa at least 5 feet (1.5m) from all metal surfaces. (A spa may be installed within 5 feet of metal surfaces if, in accordance with the National Electrical Code ANSI/NMFA70 – 1993, each metal surface is permanently connected to a minimum No. 8 AWG (8.4mm²) solid copper conductor attached to the wire connector on the terminal box that is provided for this purpose.)
10. DANGER—RISK OF ELECTRIC SHOCK. Do not permit any electric appliance, such as a light, telephone, radio, or television, within 5 feet (1.5m) of the spa or hot tub.
11. WARNING—To reduce the risk of injury:
 - The water in the spa should never exceed 40 deg. C (104 degrees F). Water temperatures between 38 deg. C (100 degrees F) and 40 deg. C (104 degrees F) are considered safe for a healthy adult. Lower water temperatures are recommended for extended use (exceeding 10 minutes) and for young children.
 - Since excessive water temperatures have a high potential for causing fetal damage during the early months of pregnancy,

pregnant or possibly pregnant women should limit spa water temperatures to 38 deg. C (100 degrees F).

- Before entering a spa, the user should measure the water temperature with an accurate thermometer since the tolerance of water temperature-regulating devices may vary as much as $\pm 3^{\circ}\text{C}$ (5° F).
 - The use of alcohol, drugs, or medication before or during spa use may lead to unconsciousness with the possibility of drowning.
 - Persons suffering from obesity or with a medical history of heart disease, low or high blood pressure, circulatory system problems or diabetes should consult a physician before using a spa.
 - Persons using medications should consult a physician before using a spa since some medication may induce drowsiness while other medication may affect heart rate, blood pressure and circulation.
12. DANGER—TO REDUCE THE RISK OF INJURY TO PERSONS. Do not remove the suction fittings (filter standpipes) located in the filter compartment!
 13. DANGER—RISK OF INJURY. The suction fittings in this spa are sized to match the specific water flow created by the pump. Should the need arise to replace the suction fittings or the pump, be sure that the flow rates are compatible.

14. SAVE THESE INSTRUCTIONS.

SAFETY SIGN: Each HOT SPRING Spa is shipped with a SAFETY SIGN in the spa's owner's package. Underwriters Laboratories recommends this sign be permanently installed where it is visible to the users of the spa. To obtain additional SAFETY SIGNS, contact your HOT SPRING dealer and request Part #34329.

TABLE OF CONTENTS

I. GENERAL INFORMATION

Personal Safety	4
-----------------------	---

II. SPA SPECIFICATIONS & ILLUSTRATIONS

Features of your	
GRANDEE (Model G)	6
HIGHLIFE (Model K)	7
CLASSIC (Model F)	8
SOVEREIGN (Model I)	9
CLASSIC (Model FH)	10
SOVEREIGN (Model IH)	10
PRODIGY (Model H)	11
JETSETTER (Model J)	12

III. INSTALLATION INSTRUCTIONS

Site Preparation/Positioning	
Your Spa	13
Electrical Requirements	
230 Volt Models	13
115 Volt Models	16

IV. OPERATING INSTRUCTIONS

General Information	17
Start-up Procedures	18
Hydrotherapy Jet System	19
JETSTREAM	19
MOTO-MASSAGE JET	20
Stationary Jets	20
Jet System Menus	
GRANDEE (Model G)	21
HIGHLIFE (Model K)	23
CLASSIC (Model F)	24
SOVEREIGN (Model I)	25
PRODIGY (Model H)	26
JETSETTER (Model J)	27
Control Panel	27
G.F.C.I.	28
Light	29
Summer Mode Switch	29

V. SPA CARE AND MAINTENANCE

General Information	30
Draining the Water	30
Filter System	30
Filter Cartridge	31
Care of the Spa Pillows	31
Care of the Exterior Finish	31
Care of the Thermal Cover	32
Prevention of Freezing	34
Winterizing	34

VI. WATER QUALITY AND MAINTENANCE

General Information	35
Spa Water Testing	35
Water Chemistry Terminology	36
Chemical Safety and Storage	37
Adding Spa Water Chemicals	37
Mineral Content	38
pH Control	38
Sanitation	39
Sanitation Table	40
Do's and Don'ts of Spa Water	
Maintenance	41
Water Purification—Ozone	41
Supplemental Water	
Maintenance	43
Spa Water Maintenance —	
Troubleshooting Guide	44

VII. SERVICE INFORMATION

General Information	45
G.F.C.I. and High Limit	
Thermostat	45
“No Fault” Heater and Flow	
Switch Controller	45
FRESH WATER System	45
Miscellaneous Service	
Information	46
Acts Invalidating Warranty	46
Disclaimers	47
Watkins Customer Service	47
Troubleshooting Guide	48

I. GENERAL INFORMATION

PERSONAL SAFETY

Prolonged immersion in water that is warmer than normal body temperature can result in a dangerous condition known as HYPERTHERMIA. The causes, symptoms, and effects of hyperthermia may be described as follows: Hyperthermia occurs when the internal temperature of the body reaches a level several degrees above the normal body temperature of 98.6 degrees F. The symptoms of hyperthermia include dizziness, fainting, drowsiness, lethargy, and an increase in the internal temperature of the body. The effects of hyperthermia include (1) unawareness of impending hazard, (2) failure to perceive heat, (3) failure to recognize the need to exit the spa, (4) physical inability to exit the spa, (5) fetal damage in pregnant women, and

(6) unconsciousness resulting in a danger of drowning. **WARNING**—The use of alcohol, drugs, or medication can greatly increase the risk of fatal hyperthermia in hot tubs and spas.

Persons taking medications which induce drowsiness such as tranquilizers, anti-histamines or anti-coagulants should not use the spa. **Pregnant women and persons with a medical history of heart disease, circulatory problems, diabetes or high blood pressure should consult their physician before using the spa.**

Children are especially sensitive to hot water. At no time should children have unsupervised access to the spa. The use of elevated decking may encourage children to climb onto the thermal cover. All HOT SPRING Spas are equipped with a locking thermal cover that meets the ASTM F1346-91 Standard for Safety Covers. Always lock the child resistant locks after using the spa for your children's safety.

DO's AND DON'T'S

- | | | | |
|-----------|--|--------------|--|
| DO | be sure your spa is connected to the power supply correctly - use a licensed electrical contractor. | DON'T | use the spa with the equipment compartment door removed (wood skirted spa models). |
| DO | disconnect the spa from the power supply before draining the spa or servicing the electrical components. | DON'T | use the spa for long periods of time at water temperatures in excess of 104 degrees F. |
| DO | test the Ground Fault Circuit Interrupter(s) monthly. | DON'T | connect your spa to an extension cord (115 volt cord and plug connected models). |
| DO | test the water temperature with your hand before entering the spa to be sure that it's comfortable. | DON'T | allow the hydrotherapy jet pump to operate for extended periods of time with the thermal cover in place. Extended pump operation will cause a slow heat buildup due to water friction. The spa equipment controls are equipped with a built-in safety timer that will automatically shut off the jet pump after two hours of continuous operation should it have been left on inadvertently. |
| DO | remember that wet surfaces can be very slippery. Take care when entering and exiting the spa. | DON'T | operate the spa at any time with the filter cartridges removed. |
| DO | use the thermal cover when the spa is not in use, empty or full. | DON'T | lift or drag the vinyl thermal cover by using the tie-down straps; always lift or carry the cover by using the handles. |
| DO | keep the water clean, clear and sanitized by correct chemical care. | DON'T | store chemicals in the spa's equipment compartment. |
| DO | turn on the 10-minute clean-up cycle when adding ALL spa water chemicals into the filter compartment. | DON'T | hesitate to call your HOT SPRING Spa representative with any questions or maintenance problems. |
| DO | follow the Spa Care and Maintenance recommendations stated in this manual. | | |
| DO | clean the filter cartridges monthly to remove debris and mineral buildup which may affect the performance of the hydrotherapy jets, trip the flow switch or trip the high-limit thermostat which will turn off the entire spa. | | |

WARNING: Watkins Manufacturing Corporation recommends that the HOT SPRING Spa be installed above ground. Lowering the top of the spa to ground level, or employing decking which raises standing level toward the top of the spa substantially increases the hazard of accidental entry. Consult a licensed building contractor to design or evaluate your custom decking requirements.

II. SPA SPECIFICATIONS

GENERAL INFORMATION AND SPA SPECIFICATIONS

MODEL	HORIZONTAL DIMENSIONS	HEIGHT	EFFECTIVE FILTER AREA	HEATER (WATTS)	WATER CAPACITY (GAL)	DRY WEIGHT (LBS)	FILLED WEIGHT (LBS)	DEAD WEIGHT (Lbs Per Sq. Ft.)	ELECTRICAL REQUIREMENTS
GRANDEE (Model G)	7' 8" x 8' 3-1/2"	36-1/2"	150 Sq. Ft.	5,500 Watt	500 Gal	820 LBS	4,990 LBS	87 LBS PER SQ. FT.	230 Volt, 50 Amp Single Phase G.F.C.I. Protected Circuit
HIGHLIFE (Model K)	8' 4" x 7' 2"	34"	120 Sq. Ft.	5,500 Watt	415 Gal	665 LBS	4,130 LBS	85 LBS PER SQ. FT.	230 Volt, 50 Amp Single Phase G.F.C.I. Protected Circuit
CLASSIC (Model F)	7' 7-1/2" x 7' 8-1/2"	31"	90 Sq. Ft.	1,500 Watt	325 Gal	455 LBS	3,170 LBS	150* LBS PER SQ. FT.	115 Volt, 20 Amp Dedicated G.F.C.I. Protected Circuit
CLASSIC (Model FH)	7' 7-1/2" x 7' 8-1/2"	31"	90 Sq. Ft.	5,500 Watt	325 Gal	455 LBS	3,170 LBS	150* LBS PER SQ. FT.	230 Volt, 50 Amp Single Phase G.F.C.I. Protected Circuit
SOVEREIGN SOVEREIGN (Model I)	6' 4" x 7' 7"	29"	90 Sq. Ft.	1,500 Watt	300 Gal	530 LBS	3,035 LBS	75 LBS PER SQ. FT.	115 Volt, 20 Amp Dedicated G.F.C.I. Protected Circuit
SOVEREIGN SOVEREIGN (Model IH)	6' 4" x 7' 7"	29"	90 Sq. Ft.	5,500 Watt	300 Gal	530 LBS	3,035 LBS	75 LBS PER SQ. FT.	230 Volt, 50 Amp Single Phase G.F.C.I. Protected Circuit
PRODIGY (Model H)	5' 11" x 6' 10"	29"	90 Sq. Ft.	1,500 Watt	295 Gal	485 LBS	2,945 LBS	75 LBS PER SQ. FT.	115 Volt, 20 Amp Dedicated G.F.C.I. Protected Circuit
JETSETTER (Model J)	5' x 6' 7"	27-1/2"	90 Sq. Ft.	1,500 Watt	205 Gal	415 LBS	2,150 LBS	75 LBS PER SQ. FT.	115 Volt, 20 Amp Dedicated G.F.C.I. Protected Circuit

*Spa weight of the CLASSIC is evenly distributed on a trapezoidal support grid (21 sq. ft. area).

CAUTION: Watkins Manufacturing Corporation suggests a structural engineer or contractor be consulted prior to the spa being placed on an elevated deck or platform.

GRANDEE Model G Overhead view

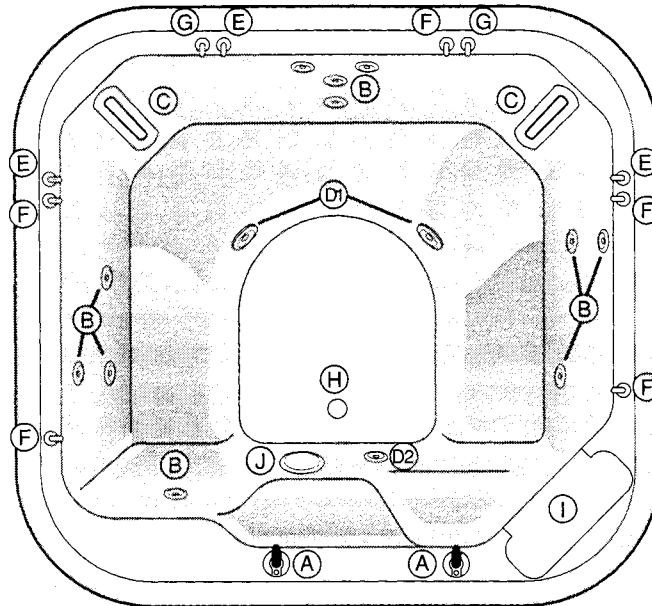

- | | | |
|---------------------------------------|--|--|
| A. JET SELECTOR Control | F. Hydrotherapy Jet Air Control Valve (Teal) | L. 5.5 KW Heater |
| B. Adjustable Hydrotherapy Jet | G. MOTO-MASSAGE Air Control Valve (White) | M. Silent-Flow 5002 Circulation Pump |
| C. MOTO-MASSAGE Jet® | H. Heater Return/Spa Drain Inlet | N. Junction Box |
| D1. Adjustable JETSTREAM Jet® | I. Filter Compartment | O. Spa Drain Valve |
| D2. Fixed JETSTREAM Jet | J. Light Lens | P. Ozone Injector (optional accessory-not installed as standard) |
| E. JETSTREAM Air Control Valve (Blue) | K. Wavemaster 7000 Jet Pump | Q. Secondary Drain |

Equipment Compartment

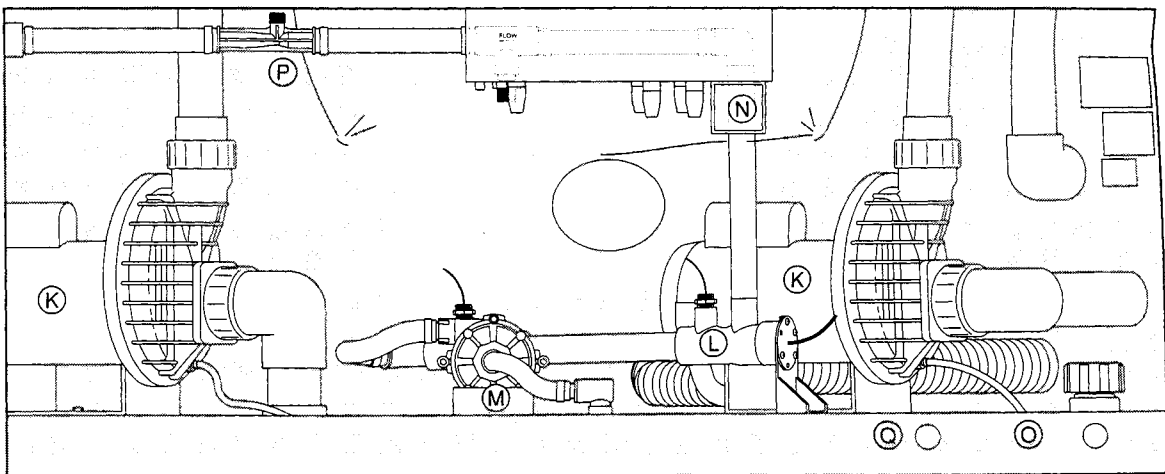

HIGHLIFE Model K Overhead view

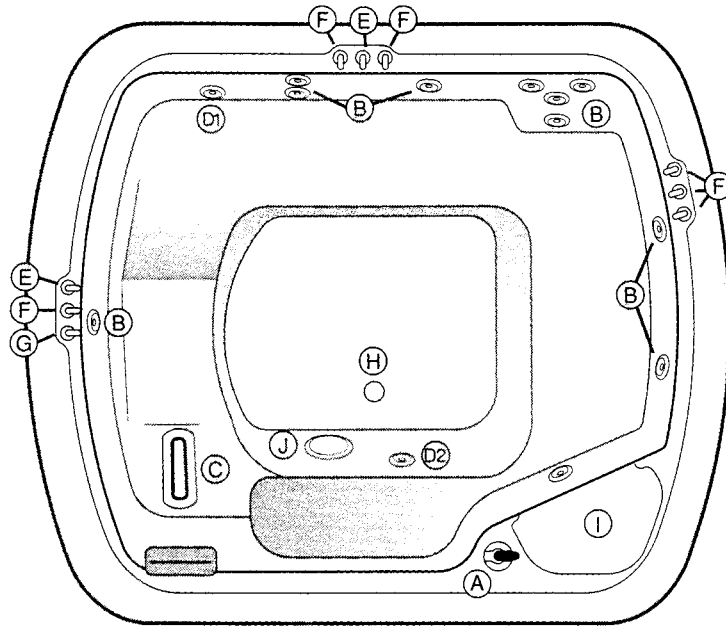

- | | | |
|---------------------------------------|--|--|
| A. JET SELECTOR Control | F. Hydrotherapy Jet Air Control Valve (Teal) | L. 5.5 KW Heater |
| B. Adjustable Hydrotherapy Jet | G. MOTO-MASSAGE Air Control Valve (White) | M. Silent-Flow 5002 Circulation Pump |
| C. MOTO-MASSAGE Jet® | H. Heater Return/Spa Drain Inlet | N. Junction Box |
| D1. Adjustable JETSTREAM Jet® | I. Filter Compartment | O. Spa Drain Valve |
| D2. Fixed JETSTREAM Jet | J. Light Lens | P. Ozone Injector (optional accessory-not installed as standard) |
| E. JETSTREAM Air Control Valve (Blue) | K. Wavemaster 9000 Jet Pump | Q. Secondary Drain |

Equipment Compartment

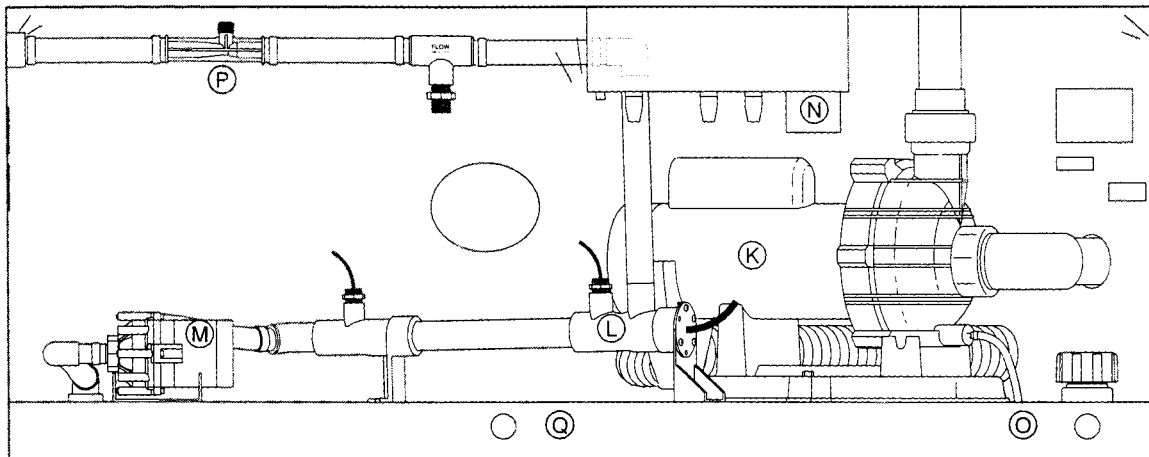

CLASSIC Model F Overhead view

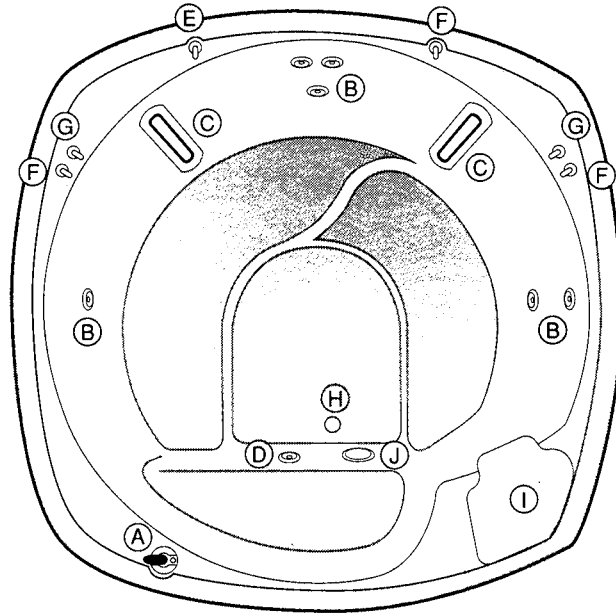

- | | | |
|--|---|--|
| A. JET SELECTOR Control | G. MOTO-MASSAGE Air Control Valve (White) | M. Silent-Flow Circulation Pump |
| B. Adjustable Hydrotherapy Jet | H. Heater Return/Spa Drain Inlet | N. G.F.C.I. |
| C. MOTO-MASSAGE Jet® | I. Filter Compartment | O. Spa Drain Valve |
| D. Adjustable JETSTREAM Jet® | J. Light Lens | P. Ozone Injector (optional accessory-not installed as standard) |
| E. JETSTREAM Air Control Valve (Blue) | K. Wavemaster 7000 Jet Pump | Q. Secondary Drain |
| F. Hydrotherapy Jet Air Control Valve (Teal) | L. 1.5 KW Heater | |

Equipment Compartment (115 Volt)

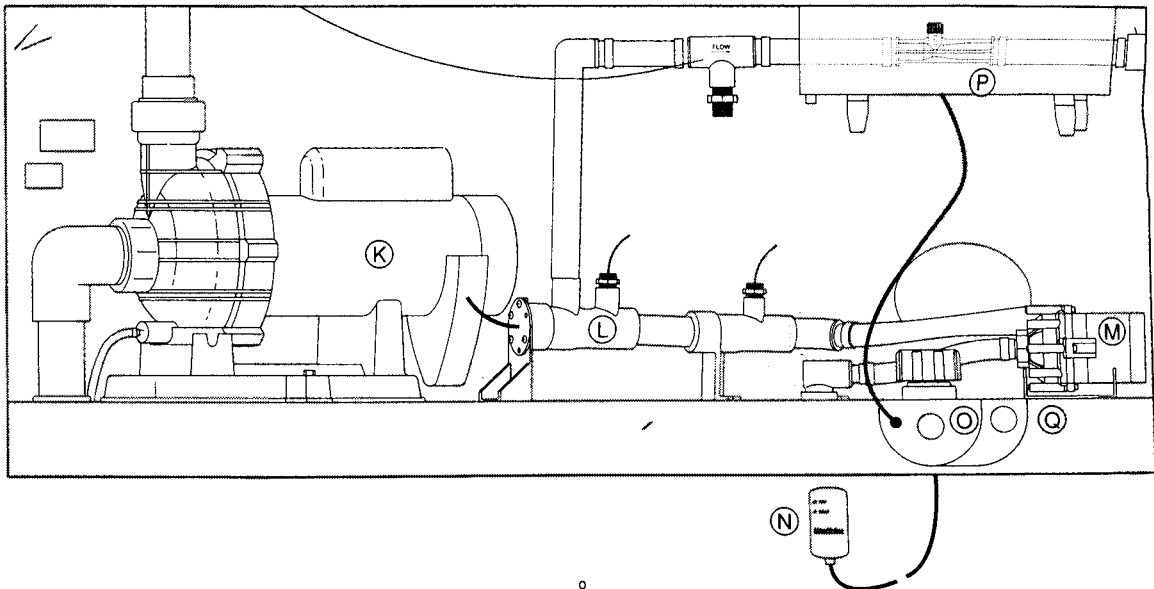

SOVEREIGN Model I Overhead view

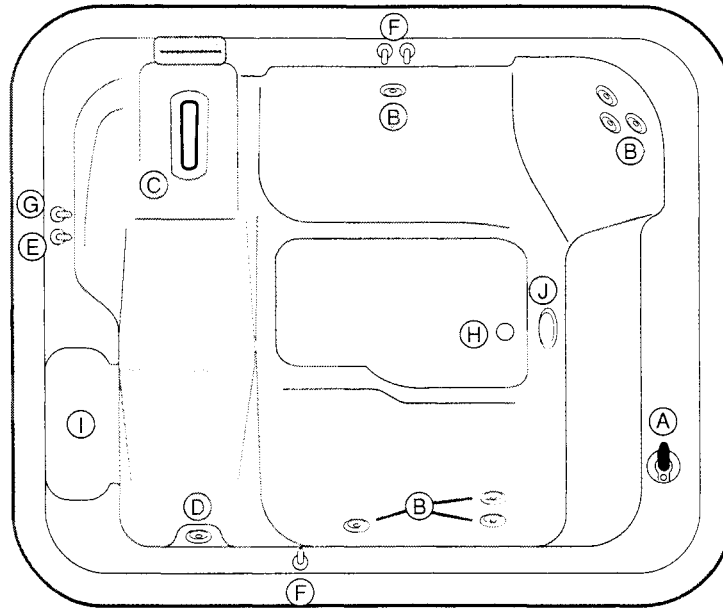

- | | | |
|--|---|--|
| A. JET SELECTOR Control | G. MOTO-MASSAGE Air Control Valve (White) | M. Silent-Flow 5000 Circulation Pump |
| B. Adjustable Hydrotherapy Jet | H. Heater Return/Spa Drain Inlet | N. G.F.C.I. |
| C. MOTO-MASSAGE Jet® | I. Filter Compartment | O. Spa Drain Valve |
| D. Adjustable JETSTREAM Jet® | J. Light Lens | P. Ozone Injector (optional accessory-not installed as standard) |
| E. JETSTREAM Air Control Valve (Blue) | K. Wavemaster 7000 Jet Pump | Q. Secondary Drain |
| F. Hydrotherapy Jet Air Control Valve (Teal) | L. 1.5 KW Heater | |

Equipment Compartment (115 Volt)

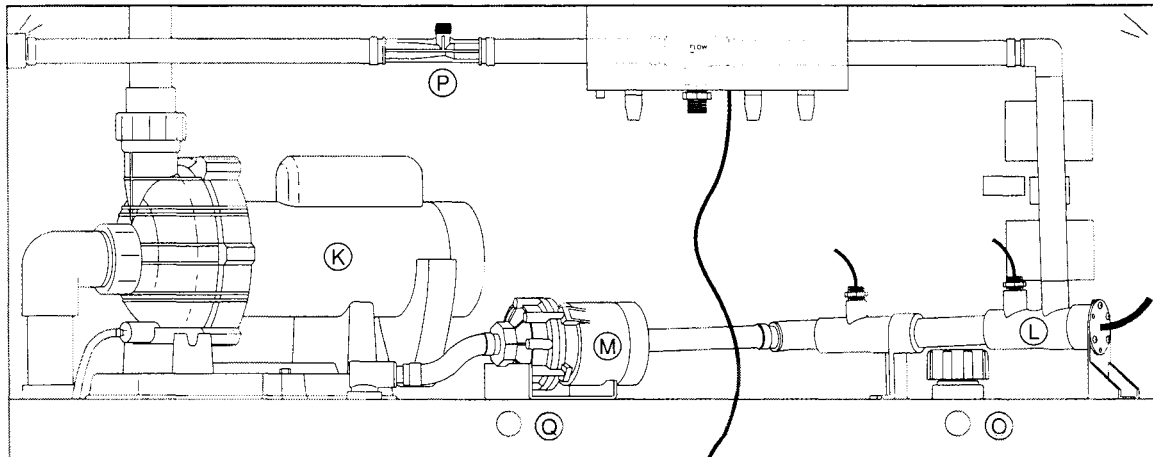

**CLASSIC Model FH
Equipment Compartment (230 Volt)**

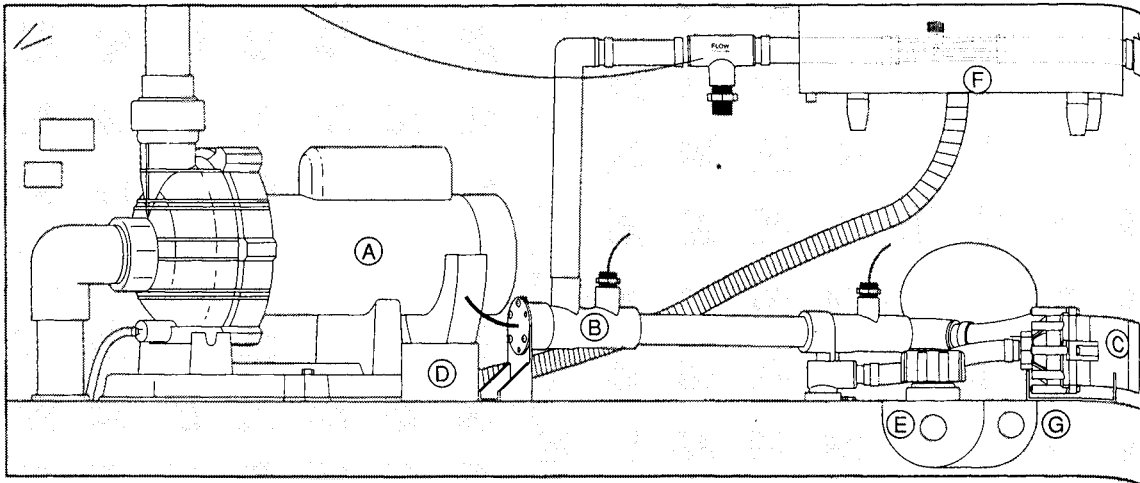

- A. Wavemaster 7000 Jet Pump
- B. 5.5 KW Heater
- C. Silent-Flow 5002 Circulation Pump
- D. Junction Box
- E. Spa Drain Valve
- F. Ozone Injector (optional accessory-not installed as standard)
- G. Secondary Drain

**SOVEREIGN Model IH
Equipment Compartment (230 Volt)**

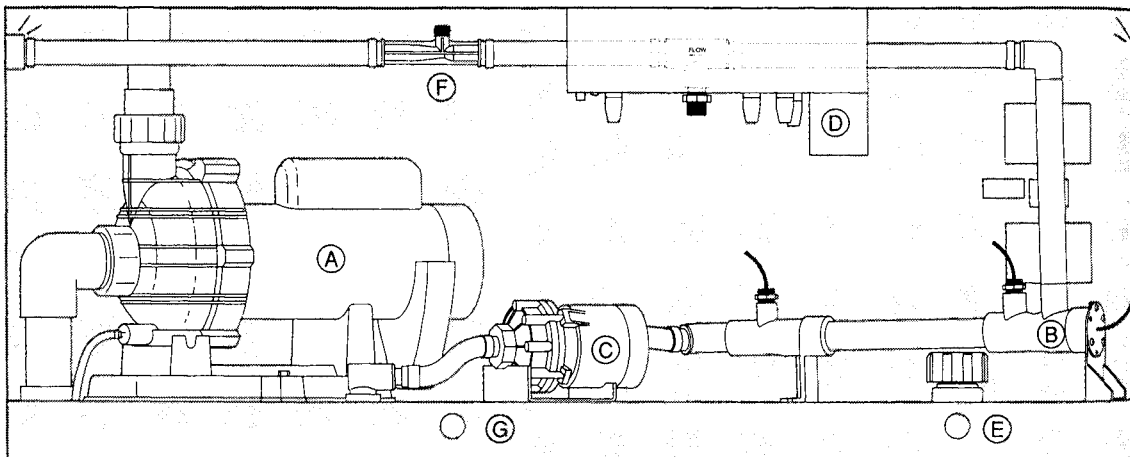

PRODIGY Model H Overhead view

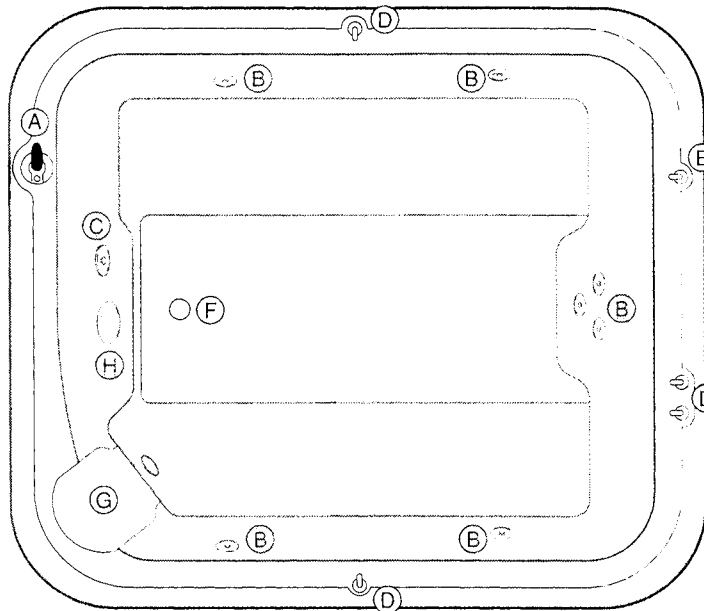

- | | | |
|---|---|--|
| A. JET SELECTOR Control | F. Heater Return/Spa Drain Inlet | L. G.F.C.I. |
| B. Adjustable Hydrotherapy Jet | G. Filter Compartment | M. Spa Drain Valve |
| C. Adjustable JETSTREAM Jet® | H. Light Lens | N. Ozone Injector (optional
accessory-not installed as
standard) |
| D. Hydrotherapy Jet Air Control
Valve (Teal) | I. Wavemater 5000 Jet Pump | O. Secondary Drain |
| E. JETSTREAM Air Control Valve
(Blue) | J. 1.5 KW Heater | |
| | K. Silent-Flow 5000
Circulation Pump | |

Equipment Compartment (115 Volt)

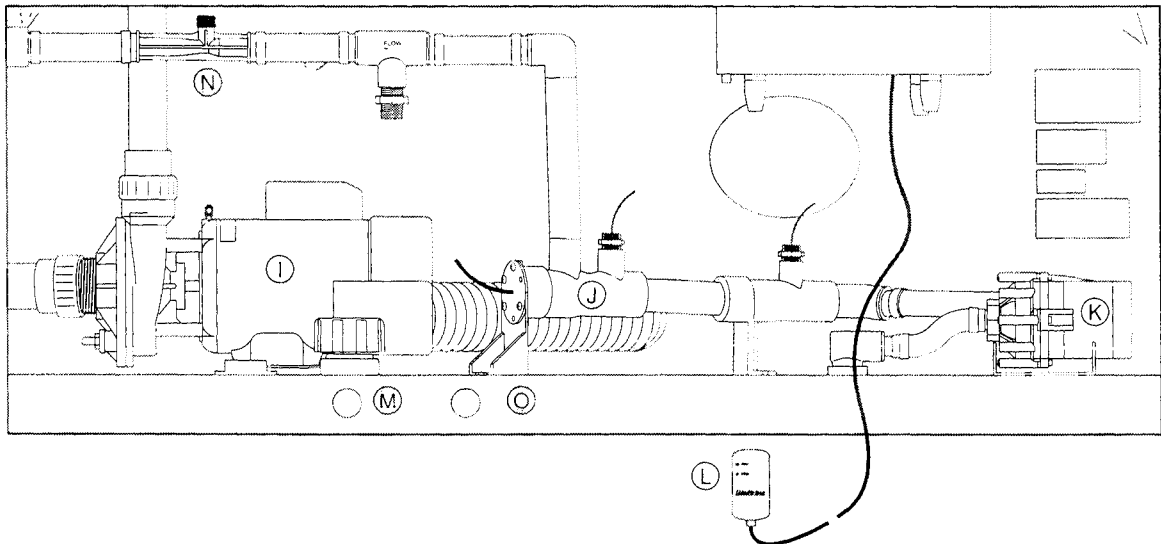

JETSETTER Model J Overhead view

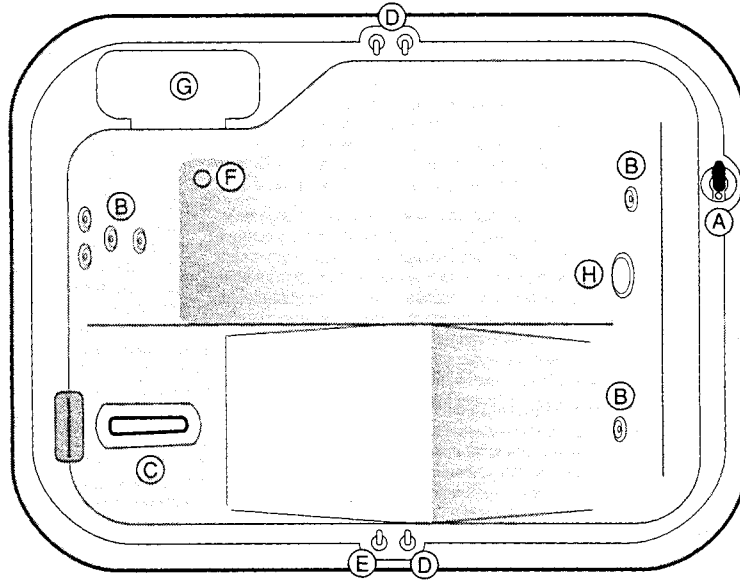

- | | | |
|--|--------------------------------------|--|
| A. JET SELECTOR Control | F. Heater Return/Spa Drain Inlet | L. G.F.C.I. |
| B. Adjustable Hydrotherapy Jet | G. Filter Compartment | M. Spa Drain Valve |
| C. MOTO-MASSAGE Jet® | H. Light Lens | N. Ozone Injector (optional accessory-not installed as standard) |
| D. Hydrotherapy Jet Air Control Valve (Teal) | I. Wavemaster 5000 Jet Pump | O. Secondary Drain |
| E. MOTO-MASSAGE Air Control Valve (White) | J. 1.5 KW Heater | |
| | K. Silent-Flow 5000 Circulation Pump | |

Equipment Compartment (115 Volt)

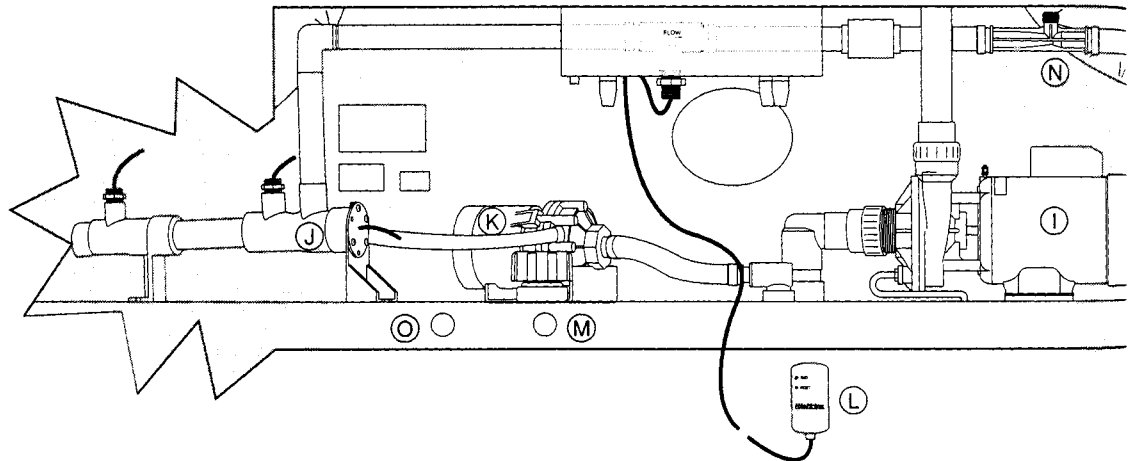

III. INSTALLATION INSTRUCTIONS

SITE PREPARATION / POSITIONING YOUR SPA

Your HOT SPRING Spa is totally self-contained and portable. You can locate it just about anywhere you wish—on a patio, deck, or even indoors. Regardless of your choice, the spa should always be placed on a structurally strong, level surface. Once in place, the spa will need to be leveled (refer to enclosed Spa Leveling Instructions). When selecting an installation site, be sure to allow for drainage away from the equipment compartment which houses the electrical components. The installation site should allow for easy access to the Ground Fault Circuit Interrupter (G.F.C.I.) breakers which are located in the subpanel on 230 volt spa models, or the 115 volt G.F.C.I. switch which is located on the end of the power cord on 115 volt spa models for monthly testing. The 115 volt G.F.C.I. switch and the receptacle it is plugged into must be protected from weather and landscape sprinklers—they should never get wet. The 230 volt G.F.C.I. subpanel is a "Raintight" rated enclosure when installed correctly and the panel door is closed securely. Allowing moisture to enter either the subpanel or receptacle will result in tripping of the main circuit breaker in the house electric panel. Allow for access to the equipment compartment for periodic spa care and maintenance.

Outdoor/Patio Installation

If you install the spa outdoors, we recommend that you provide a reinforced 3"-4" thick concrete pad. (Attach bond wire to mesh. See pg. 2, item 4.) Should it be necessary to temporarily place the spa on a soft surface (grass, dirt, etc.) 2" x 12" x 12" stepping stones should be placed at the designated leveling areas (see Spa Leveling Instructions). It is important to note that soft foundations, even when stepping stones are used to evenly distribute the weight of the spa, will still have a tendency to settle thus resulting in an unlevel spa. Also, placing the spa on grass or dirt may increase the amount of debris which is inadvertently brought into the spa water on users' feet.

Your HOT SPRING Spa dealer may offer a variety of Specialty Wood Products and enclosures. These include free-standing gazebos, skirt mounted gazebos, spa enclosures, spa settings and decks. Should you have your spa installed with any of these accessory items, a solid foundation is mandatory to ensure stability of the structure or deck.

NOTE: Structural damage to the spa resulting from incorrect installation or placement on an inadequate foundation is not covered under the spa's 5 year limited structure warranty.

Deck Installation

Please refer to the Spa Specification Section of this manual for the dead weight per square foot. These figures do not take into consideration occupant weight. Should you be unsure of your deck's maximum load capacity, please consult a qualified building contractor or structural engineer.

Indoor Installation

Water which splashes on the floor during use of the spa may cause a walking hazard and/or structural damage to the dwelling unless good drainage is provided. Proper building materials must be used in the area surrounding and beneath the spa. Take into consideration the room humidity which will exist due to high spa water temperatures. Providing natural or forced ventilation into the room will help maintain comfort and minimize moisture damage to the building. Consult an architect for aid in designing your indoor spa or garden room.

IMPORTANT: HOT SPRING Spas are equipped with a jet pump shroud to evacuate excessive heat from the equipment compartment. This feature reduces the possibility of overheating pump motors and protects all other components from the effects of excessive heat. The vent for this pump shroud is located under the bottom corner of wood-skirted spa models and directly below the equipment compartment on the Classic model. When installing your spa, ensure any masonry, decking or grass which may surround your spa is not allowed to block the vent.

NOTE: Your HOT SPRING Spa dealer can answer many of your questions regarding local zoning requirements and building codes. In addition, the following planning aid is available from your dealer:

- HOT SPRING Spa – Pre-Delivery Instructions

ELECTRICAL REQUIREMENTS AND PRECAUTIONS

GENERAL INFORMATION

Your HOT SPRING Spa has been carefully engineered to provide maximum safety against electric shock. Remember, connecting the spa to an improperly wired circuit will negate many of its safety features. Please read and follow the electrical installation requirements and instructions for your specific spa model completely!

230 VOLT MODELS
GRANDEE (Model G)
HIGHLIFE (Model K)
CLASSIC (Model FH)
SOVEREIGN (Model IH)

Electrical Requirements

HOT SPRING SPAS MUST BE WIRED IN ACCORDANCE WITH ALL APPLICABLE, LOCAL ELECTRICAL CODES. ALL ELECTRICAL WORK SHOULD BE DONE BY AN EXPERIENCED, LICENSED ELECTRICIAN. WE RECOMMEND THE USE OF APPROPRIATE ELECTRICAL CONDUIT, FITTINGS, AND WIRE FOR ALL CIRCUITS.

An electrical subpanel containing 2 G.F.C.I. breakers is included with the spa. WE RECOMMEND THAT THIS SUBPANEL BE USED TO SUPPLY POWER AND PROTECT THE SPA.

This subpanel requires a 50 amp, single phase, 230 Volt, four wire service (two line, one neutral, one ground). The grounding conductor must be the same gauge as the line conductors, but no smaller than a #8 AWG. A #8 solid copper bond wire will also be required.

MOUNT THE SUBPANEL ACCORDING TO LOCAL CODES IN THE VICINITY OF THE SPA, BUT NOT CLOSER THAN FIVE FEET. (NEC 680-6c)

Installation Instructions

1. To connect the electrical service, first remove the screws from the equipment access door. On the CLASSIC model, lift and prop the door in the open position. On the wood skirted models, carefully pull the door panel away and down to remove it completely from the spa.
2. Locate and remove the junction box cover. (On the GRANDEE, HIGHLIFE, and SOVEREIGN "IH" models, the junction box is attached to the control box. The junction box is located on the floor of the equipment compartment on the CLASSIC "FH" model.)
3. Route the supply conduit from the subpanel into the spa's equipment compartment. (On the GRANDEE, HIGHLIFE and SOVEREIGN "IH" models, route the conduit through the access opening between the door frame and the equipment compartment. On the CLASSIC "FH" model, the supply conduit should be brought up through the opening in the floor of the equipment compartment. Install the supply conduit so as not to block the drain valve.)
4. Connect the supply conduit to the spa's flexible conduit which exits the bottom of the junction box on the GRANDEE, HIGHLIFE, and SOVEREIGN "IH" models, or connect it directly to the junction box on the CLASSIC "FH" model.

Wiring Connections

1. Connect the two solid #10 AWG copper wires from the 230 Volt, 30 amp, G.F.C.I. breaker to the #10 AWG, blue and red leads in the junction box.

2. Connect the two solid #12 AWG copper wires from the 230 Volt, 20 amp, G.F.C.I. breaker to the #12 AWG, blue and red leads in the junction box.
3. Connect the #12 AWG white copper wire lead in the junction box to the 230 Volt, 20 amp, G.F.C.I. breaker.

NOTE: The white neutral wire must be attached to the LOAD neutral on the 230 Volt, 20 amp breaker (not the neutral bus bar in the subpanel). The white neutral wire from the breaker is then connected to the neutral bus bar.

4. Connect the green ground wire from the ground bus bar in the subpanel to the green grounding screw in the wiring box. It is absolutely essential that a good quality ground connection be made.
5. Bond the spa to all exposed metal equipment or fixtures, handrails, and concrete pad per N.E.C. Article 680.
6. Replace the junction box cover, close or replace the equipment access door panel.

Turn on and test all breakers once the spa has been filled with water. Each of the G.F.C.I. breakers should be tested monthly. To test, simply push the "test" button on each of the G.F.C.I.s. The switch should click over to the trip position thus shutting off power to the circuit. Wait 30 seconds then reset the G.F.C.I. breakers by switching completely off and then completely on. If any of the G.F.C.I.s fail to operate in this manner, your spa may have an electrical malfunction, indicating the risk of electric shock. Turn off all circuits and do not use the spa until the malfunction has been corrected by an authorized service agent.

WARNING: Removing or bypassing the G.F.C.I. breaker in the subpanel at any time will result in an unsafe spa and will void the warranty.

IMPORTANT: Should you ever find occasion to move or relocate your HOT SPRING Spa, it is essential you understand and apply its installation requirements.

WIRE SPECIFICATION NOTE: Long electrical wiring runs may require a larger gauge feed wire than stated. We recommend that a maximum voltage drop of 3% be used when calculating the larger wire size.

**GRANDEE (Model G), HIGHLIFE (Model K),
CLASSIC (Model FH) and SOVEREIGN (Model IH)**

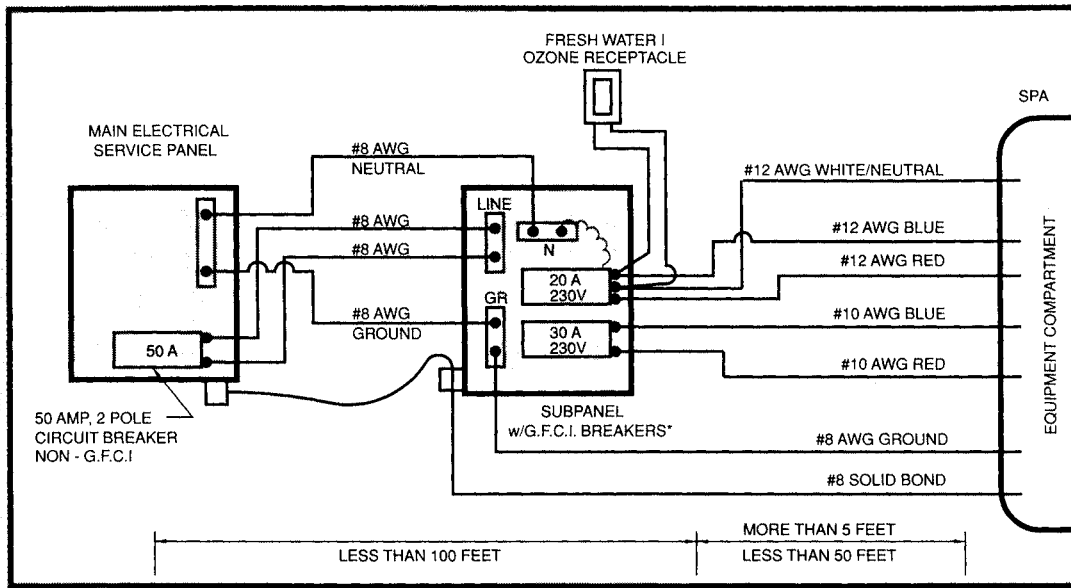

*PROVIDED WITH SPA NOTE: ALL WIRING SHOULD BE COPPER

**115 VOLT MODELS
CLASSIC (Model F)
SOVEREIGN (Model I)
PRODIGY (Model H)
JETSETTER (Model J)**

Electrical Requirements

The spa must be connected to a "dedicated" 115 Volt, 20 amp G.F.C.I. protected, grounded circuit. The term "dedicated" means the electrical circuit is not being used or shared for any other electrical items (patio lights, appliances, garage circuits, etc.). If the spa is connected to a non-dedicated circuit, overloading will result in "nuisance tripping" which requires resetting of the breaker switch at the house electrical breaker panel and possible damage or failure of spa equipment. The dedicated circuit must be properly wired; that is, it must have a 20 amp G.F.C.I. circuit breaker in the house breaker panel, #12 AWG or larger wire (including the ground wire) and the correct polarity throughout the circuit. The optional FRESH WATER I Ozone Purification System may also be connected to the spa circuit. The FRESH WATER II Ozone System, which can be installed within the equipment compartment, will plug into the spa's electrical control box.

**NEVER CONNECT THE SPA TO AN
EXTENSION CORD!**

A pressure wire connector is provided on the exterior surface of the control box, inside the spa. This is to permit the connection of a bonding wire between this point and any metal equipment, enclosures, pipe or conduit within five feet of the spa (if needed to comply with local building code requirements). The bonding wire must be at least a #8 AWG solid copper wire.

Installation Instructions

Each HOT SPRING Spa, 115 Volt model, comes equipped with approximately 15 feet of usable power cord (this is the maximum length allowed by Underwriters Laboratory and the National Electric Code). When the spa is installed, the power cord (on the redwood skirted models) will come out of the bottom of the equipment compartment door. On the CLASSIC, the power cord should be removed from the equipment compartment and brought out **under** the spa skirt (directly below the compartment door) before the spa is filled with water. For your safety, when your electrician is installing the 20 amp single electrical outlet and weatherproof cover OUTDOORS, it should be no closer than ten (10) feet and no farther than fifteen feet from the spa. If the spa is being installed INDOORS, the outlet should be no closer than five (5) feet and no farther away than (10) feet from the spa. [Reference National Electrical Code 680-6a(1) and 680-41a.]

The Ground Fault Circuit Interrupter (G.F.C.I.) is located at the end of the power cord. This device is for your protection. It is very important to protect it from rain and other moisture. Once a month, with the plug connected to the power supply, push the "Test" button located on the G.F.C.I. The unit should stop operating and the G.F.C.I. L.E.D. indicator will go out. Next, wait 30 seconds and then push the "Reset" button. Power will be restored to the spa. If the interrupter fails to operate in this manner, there may be a ground fault indicating the risk of an electric shock. Disconnect the plug from the receptacle until the source of the malfunction has been identified and corrected by an authorized service agent.

WARNING: Removal of the G.F.C.I. from the spa power cord at any time will result in an unsafe spa and void the warranty.

IMPORTANT: Should you ever find occasion to move or relocate your HOT SPRING Spa, it is essential that you understand and apply its installation requirements.

SERVICE NOTE: All HOT SPRING Spa models are equipped with a power-on indicator which, in addition to showing the spa has power to it, has a diagnostic function as well. It will begin blinking if the heater high-limit thermostat has tripped. If the power-on indicator light is blinking, follow the instructions in the troubleshooting section to identify and correct the cause. The indicator will stop blinking once the problem has been corrected.

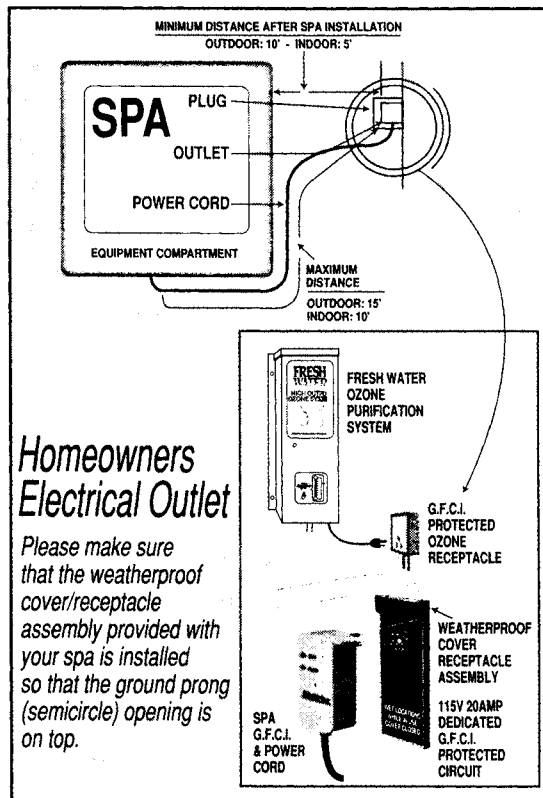

IV. OPERATING INSTRUCTIONS

GENERAL INFORMATION

HOT SPRING Portable Spas are manufactured in two different electrical versions. The largest spa models, the GRANDEE and HIGHLIFE, are available only with a 230 Volt continuous heating system.

The mid-sized spa models, the CLASSIC and SOVEREIGN, are available in either the standard 115 Volt system or a 230 Volt continuous heating system. The smaller water capacity spas, the PRODIGY and JETSETTER, are available only in the standard 115 Volt system. Each electrical system is designed to operate a specific way — the systems are not convertible.

GRANDEE (Model G) HIGHLIFE (Model K) CLASSIC (Model FH) SOVEREIGN (Model IH)

All 230 Volt HOT SPRING Spa models come standard with a subpanel which contains two G.F.C.I. circuit breakers. They utilize a subpanel that is equipped with a 20 Amp/230 Volt G.F.C.I. circuit breaker for the jet pump and control circuit and a 30 Amp/230 Volt G.F.C.I. breaker for the heating system. The subpanel and spa must be "hardwired" using appropriate wire, conduit and fittings by a licensed electrician.

The GRANDEE's dual 1 HP Wavemaster 7000 jet pump systems allow you to operate each half of the spa separately, or both halves simultaneously. Each half of the spa has four different jet systems which are selected with the Jet Selector and adjustable Jetstream.

The HIGHLIFE utilizes a single 2 HP Wavemaster 9000 jet pump to operate its multi-jet system. As with the GRANDEE, the multiple jet systems are selected with the Jet Selector and adjustable Jetstream.

The four 230 Volt spa models are equipped with a "No Fault" stainless steel, high watt density heater core. The heating system consists of a 5,500 watt (5.5 kw) heater and hybrid polymer housing, an electronic thermostat for maintaining water temperature, and a heater high-limit thermostat and flow switch controller for user and equipment protection. Most importantly, they are equipped with a two-speed Silent Flo 5002 circulation pump. This innovative pump design provides two very important functions. First, when the spa is not being used, the circulating pump will operate on low speed as part of the spa's 24 hour continuous filtration system. Secondly, when the thermostat senses a demand for heat, it will activate both the heater and the high speed of the Silent Flo circulation pump to quickly bring the spa water back up to temperature.

By utilizing two speeds, the circulating pump will be operating at peak energy efficiency most of the time because it will be on low speed and the heater will not be on. Even when it is on high speed simultaneously with the heater, it is still technically efficient because the water heat-up will be accomplished in the shortest time possible. Because the spa models are equipped with a 230 Volt, 5.5 kw heating system, the heater will also turn on while the jet pump is operating (after a 1 degree temperature drop) to help maintain the water temperature during spa use. Factors such as the number of people using the spa, the ambient temperature and the length of time the jet pump is operated, will all contribute to the heating system's ability to maintain the water temperature.

CLASSIC (Model F) SOVEREIGN (Model I) PRODIGY (Model H) JETSETTER (Model J)

All four 115 Volt spa models utilize a Wavemaster 1 HP jet pump to operate their multiple jet systems. They are manufactured with a 115 Volt, cord and plug connected electrical system. The heating system in these spa models utilize a Watkins "No Fault" heater design. This state-of-the-art heating system, incorporates an exclusive "No Fault" stainless steel, 1,500 watt (1.5 kw) heater core that is practically impervious to scaling and corrosion which are the two major causes of heater failure. The heater housing is manufactured from a flame retardant hybrid polymer for strength and durability as it will never corrode. The new heating system is also more efficient than the heating components used in past years. Spa water heat-up/temperature gain (either after original fill or after thermostat demand) occurs up to 25% faster than previous year spa models. The other components that make up the heating system include an energy efficient low-flow heater circulation pump, an electronic thermostat for maintaining water temperature, and a heater high-limit thermostat and flow switch controller for spa user and system protection.

A 115 Volt electrical system is considered an "either/or" hydrotherapy system. That is, either the hydrotherapy jet pump can be operated or the heating system. The heater does not operate at the same time the hydrotherapy pump is operating. The Silent Flo circulation pump will run continuously (even when the jet pump is operating) as part of the 24 hour continuous filtration system. (Refer to the Service Information Section in this manual for more information on warranty service of the "No Fault" heater.)

START-UP PROCEDURES

The water level of your HOT SPRING Spa should be maintained approximately four inches below the top of the spa. The bottom of the tile line of the CLASSIC or the middle of the tile on all wood skirted models can be used for easy reference.

CAUTIONS:

- Do not fill the spa with hot water as tripping of the high-limit thermostat may result.
- Do not connect power to an empty spa.
- Before using your spa after filling, super chlorinate the spa water to ensure all bacteria and contaminants have been oxidized. (See Water Quality and Maintenance Section.)

Step 1: Fill the spa with tap water.

NOTE: Watkins Manufacturing Corporation does not recommend the spa be filled with "softened" water.

Step 2: Once the spa has been filled with water, the equipment compartment door secured, power must be supplied to the spa.

- 115 Volt Models (F,I,H,J)—Connect the plug to the house receptacle and push the "reset" button on the G.F.C.I.
- 230 Volt Models (G,K,FH,IH)—Open the door of the electrical subpanel and "reset" the two G.F.C.I. breakers. Close and secure the subpanel door.

Step 3: The jet pump(s), heating system, and all internal plumbing will prime automatically during the filling of the spa with water. To check the operation of the jet system (and purge any remaining air from the heating system) push in Jet Switch #1 (also #2 switch for the GRANDEE) and wait one minute.

Once the hydrotherapy jet system is fully operational (as indicated by strong, non-surgings jets), priming of the spa is complete.

IMPORTANT: Be sure the air control valves are open by turning each one to the right and that the JET SELECTOR Control lever is pointing toward the middle of the spa's bar top (toward light lens).

SERVICE NOTES:

1. *If there is a large pocket of air trapped in the circulating pump plumbing after filling the spa with water, the flow switch will automatically shut off and prevent the heater from energizing. The air lock will eventually cause the circulating pump's thermal overload to trip and shut down the pump as well. The circulating pump will start up automatically once it has cooled. The air lock will need to be removed in order to avoid a reoccurrence.*
2. *Weak or surging jets are an indication of a low water level condition or clogged filter cartridges.*

Step 4: IMPORTANT: Adjust Total Alkalinity (T.A.), Calcium Hardness, then spa water pH and finally sanitize (super-chlorinate) the spa water by following the procedures listed in the Water Quality and Maintenance Section. The jet switch marked Clean-up Cycle should be used for the 10 minute "shock treatment".

OPERATION NOTE: Adjusting the Total Alkalinity as the first step is important, as out-of-balance TA will affect your ability to adjust the pH correctly and prevent the chlorine from sanitizing effectively.

Step 5: Once the spa plumbing and pumps have been primed, the water sanitized, and the jet pump has shut off, the thermal cover should be put on the spa. Always secure the cover in place using the cover tie-downs whenever the spa is not being used.

Step 6: Push in and turn the "TEMP" dial on the control panel to number 5. Within 18 to 24 hours, the water will reach a temperature of **approximately** 100 degrees F. A water temperature not exceeding 104 degrees F can be achieved by setting the "TEMP" dial not higher than number 7. If you find that you prefer cooler water, rotate the temperature control toward the next lower number. Conversely, if you prefer warmer water, rotate the temperature control toward the next higher number. Remember that a small change of the temperature control will yield a difference of several degrees, so make small adjustments until you find your preferred temperature. Allow several hours between adjustments. Thereafter, the water will remain within one degree of your selected temperature. **Please note, the numbers around the temperature dial are reference points to be used during temperature adjustments. They do not reflect the actual water temperature of the spa.**

SERVICE NOTE: *The hinged equipment compartment door on the HOT SPRING Spa CLASSIC is constructed of a molded ENDUROL thermoplastic sheet. Over a period of time the spa may settle (or the door may be extremely rigid because of cold weather) which will result in the screw holes on the door not aligning with screw holes around the compartment perimeter. If this situation occurs, the door may be difficult to secure completely. To align the screw holes, place your knee just below the center of the door. While pushing gently with your knee (to spread the door slightly), insert the door screws and thread them finger-tight. Remove your knee and then secure the screws completely.*

NOTE: Allowing the hydrotherapy jet pump to operate for long uninterrupted periods of time with the thermal cover in place, will cause a rise in the spa water temperature. All spas are equipped with a safety device to reduce the risk of component damage or personal injury should the jet pump be left running continuously for a long period of time. After two hours of continuous operation, the jet pump controller will automatically turn off the jet pump(s).

HYDROTHERAPY JET SYSTEM GENERAL INFORMATION

HOT SPRING Spas incorporate an exclusive SMART JET® hydrotherapy design. This SMART JET technology integrates a number of jet types (Moto-Massage, Adjustable and Standard JETSTREAMS, and Fixed Hydrotherapy Jets), a variety of jet systems (stacked jets, 3 Jet Cluster), variable Air Controls and a balanced pressure design. By incorporating positive-closing check valves in-line with the different jet systems and a JETSTREAM Jet that also functions as a diverter valve (not available on JETSETTER model), a number of jet options are available for your use.

The new SMART JET® design uses the JET SELECTOR to access the Primary Jet Mode, which is a combination of fixed jets (not the 3 Jet Cluster) and the Moto-Massage Jet(s) (not available on PRODIGY model). The JET SELECTOR handle should be pointing towards the middle of the spa to activate the Primary Jet Mode. When the JET SELECTOR handle is rotated to the other side, the Secondary Jet Mode is activated. On all HOT SPRING Spas except for the JETSETTER model, the Secondary Jet Mode consists of three different jet system combinations which are selected by turning the Adjustable JETSTREAM Jet 180 degrees. Because the JETSETTER does not incorporate a JETSTREAM Jet, it has only two modes, both determined by the JET SELECTOR.

The Air Control Valves are color coded and for simplicity, are used to control the intensity of the same jets every time. All fixed jets are controlled by **teal** color air levers, all JETSTREAMS by **blue** air levers and all Moto-Massage jets by **white** air levers. Turning the air lever towards the left will increase the jet intensity and turning it towards the right will restrict the air flow and result in a softer-feeling jet (the water volume and pressure will remain constant).

JETSTREAM®

(Not Available on JETSETTER)

The HOT SPRING GRANDEE and HIGHLIFE models utilize two types of JETSTREAM Jets. The standard JETSTREAM is a large-orifice, high-pressure jet that is designed to provide maximum massage on a specific area of the body. It is adjustable both directionally at the nozzle and in intensity with the use of the Air Control.

The second type of JETSTREAM (referred to as an Adjustable JETSTREAM) is also the selector for the Secondary Jet Mode multi-jet systems. With the JET SELECTOR pointing away from the middle of the spa, slowly rotate the Adjustable JETSTREAM fascia 180 degrees (see drawing). A different jet system will be activated at "full left," "midway," and "full right." The jet system that includes the Adjustable JETSTREAM will be activated at the center setting.

The CLASSIC, SOVEREIGN and PRODIGY models all utilize a single, Adjustable JETSTREAM to activate the three jet systems on their Secondary Jet mode.

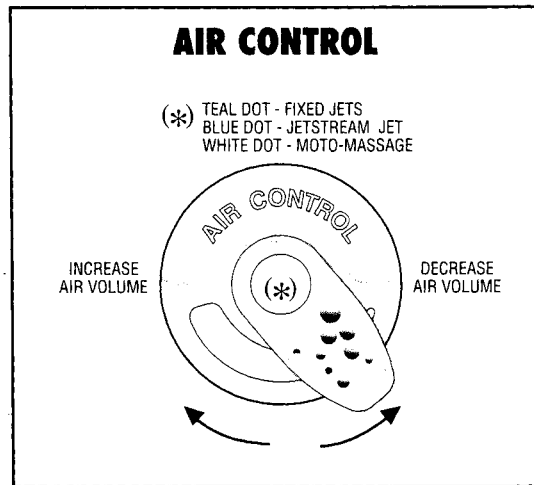
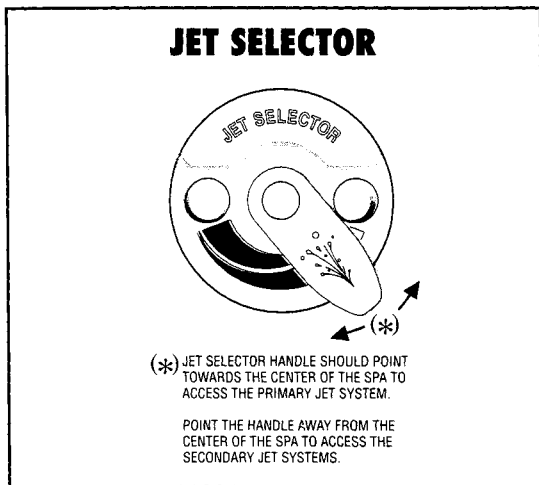
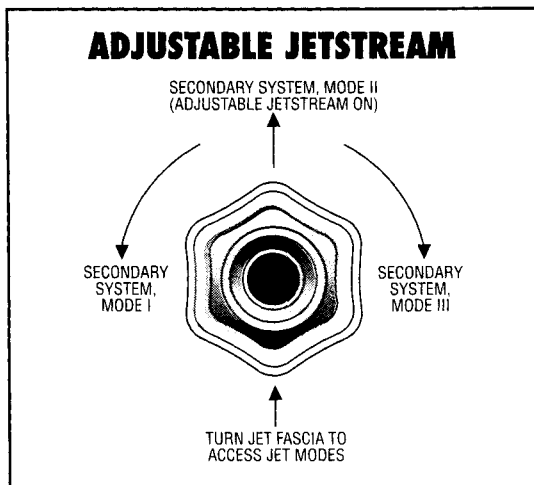

SERVICE NOTE: The Adjustable JETSTREAM fascia is designed to "pop out" of the recess should the water flow be completely blocked at the nozzle. This automatic release mechanism prevents the high volume of water from backing into the jet's air line. If the jet fascia pops out as a result of restricted water flow, turn off the jet pump, insert the fascia assembly into the jet recess and rotate it until it snaps back into place.

MOTO-MASSAGE JET® (Not Available on PRODIGY)

The MOTO-MASSAGE JET automatically travels up and down in a sweeping motion. This gentle reciprocating action simulates the natural stroking effects of a manual massage. The intensity and speed of the MOTO-MASSAGE JET can be adjusted by either restricting or opening the air control valve.

The MOTO-MASSAGE JET has been factory adjusted to provide maximum hydrotherapy. This jet has been designed and engineered to achieve full vertical travel with the designated air control valve open. Should the MOTO-MASSAGE JET not achieve full vertical travel and the problem has **not been** identified as a closed air control valve or clogged filter cartridge, then your HOT SPRING Spa Service Center should be contacted.

SERVICE NOTE: If the MOTO-MASSAGE JET suddenly ceases to move while in use (but the water pressure remains strong) and the air control valve is open, then the jet air line may have pulled away from the main air supply line. To inspect:

1. Using a standard screwdriver, remove the face plate screwhead covers.
2. Remove the two screws which secure the MOTO-MASSAGE face plate to the guide body. Then remove the face plate.
3. Remove the four guide body screws and remove the guide body.
4. Reach into the jet recess and locate the thin, unbraced tube. In the correct position, it should be attached to the plastic air line nipple located at the back of the recess. If it is not, then the air line should be gently pushed onto the nipple. Note, do not push the tube on so far as to cause the MOTO-MASSAGE JET braces to bind.
5. Reinstall the guide body (no adjustment is necessary) and the face plate.

SERVICE NOTE: A slow or non-moving MOTO-MASSAGE JET may indicate the filter cartridge pores are being obstructed with dirt, body oils, or calcification. Follow the filter cartridge cleaning procedures in the Spa Care and Maintenance Section of this manual.

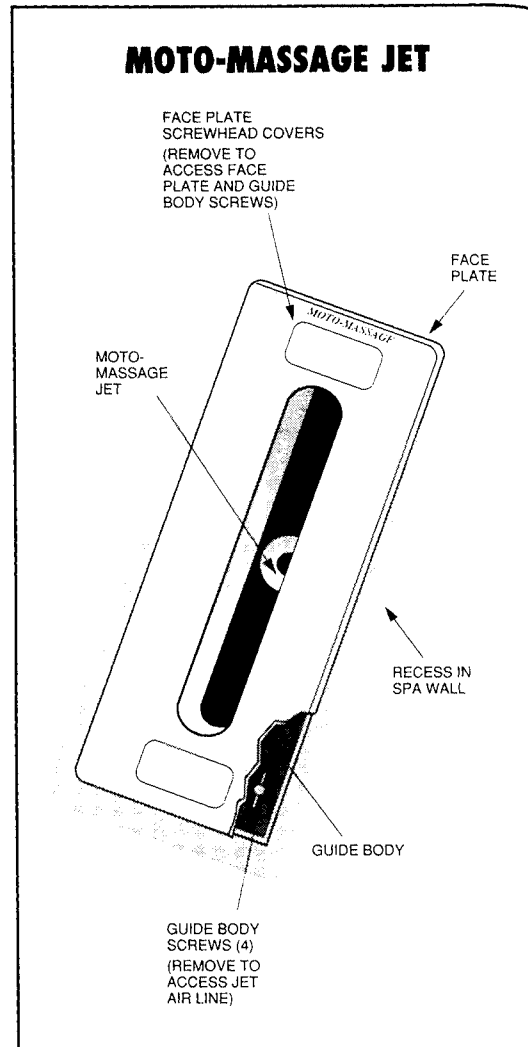

STATIONARY JETS

The stationary hydrotherapy jets (also referred to as fixed jets) are adjustable. The intensity of these jets is determined by the volume of air being induced into the jet chambers and mixing with the water stream. The air control valve can be utilized to change the intensity of a set of stationary jets simultaneously.

ACCESSORY NOTE: Your HOT SPRING Spa dealer stocks Micro'ssage Rotating Jet kits which can be easily installed in your spa in place of a stationary jet to vary your jet options.

Refer to the drawings on the following pages to familiarize yourself with the hydrotherapy jet systems for your spa. Please note that the control panel side of the spa is always considered the "front" when referring to the locations of the different types of jets or jet systems.

GRANDEE (MODEL G) JET SYSTEM MENU

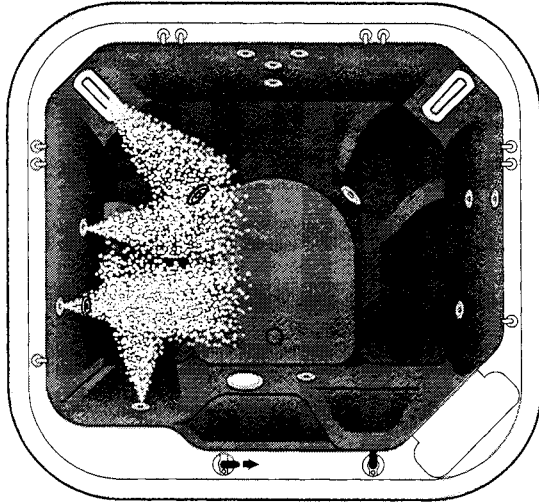

CONTROL PANEL

SYSTEM 1: Primary Mode, Left Jet Pump
 Jets:
 1 Moto-Massage
 2 Fixed, Stacked on left wall
 1 Fixed Jet on left wall
 1 Fixed Jet on pseudo lounge wall

Left Jet Selector handle right (in)

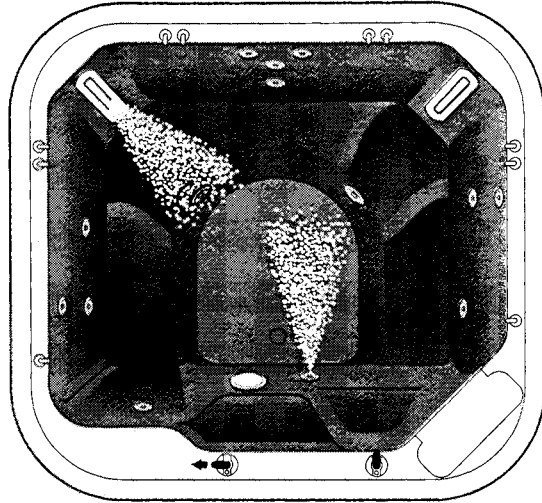

SYSTEM 2: Secondary, Mode I, Left Jet Pump
 Jets:
 1 Moto-Massage
 1 Foot Jetstream

Left Jet Selector handle left (out)
 (*)Left Calf Jetstream diverter left

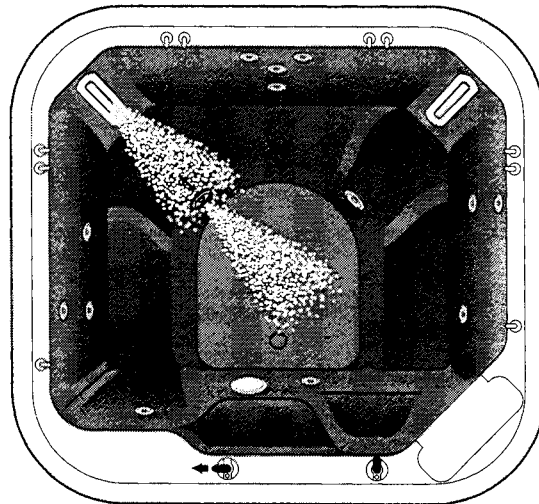

SYSTEM 3: Secondary, Mode II, Left Jet Pump
 Jets:
 1 Moto-Massage
 1 Calf Jetstream

Left Jet Selector handle left (out)
 (*)Left Calf Jetstream diverter on
 (center position)

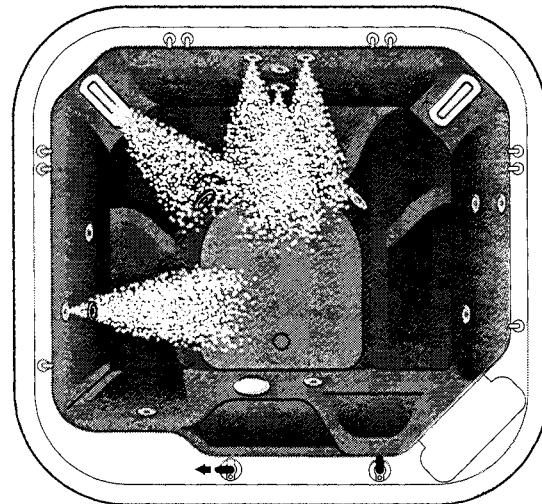

SYSTEM 4: Secondary, Mode III, Left Jet Pump
 Jets:
 1 Moto-Massage
 2 Fixed, Stacked on left wall
 3 Jet Cluster

Left Jet Selector handle left (out)
 (*)Left Calf Jetstream diverter right

GRANDEE (MODEL G) JET SYSTEM MENU (Cont.)

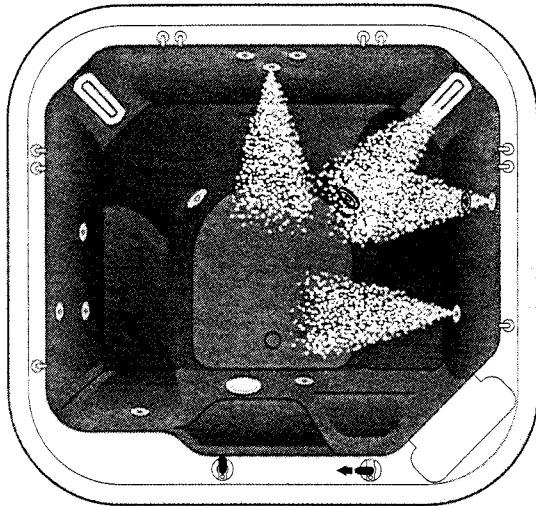

CONTROL PANEL

SYSTEM 5: Primary Mode, Right Jet Pump
 Jets:
 1 Moto-Massage
 2 Fixed, Stacked on right wall
 1 Fixed Jet on right wall
 1 Fixed Jet, Center of 3 Jet Cluster

Right Jet Selector handle left (in)

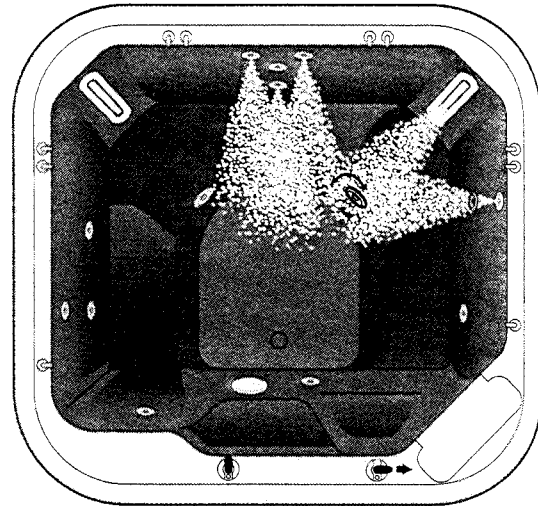

SYSTEM 6: Secondary, Mode I, Right Jet Pump
 Jets:
 1 Moto-Massage
 2 Fixed, Stacked on right wall
 3 Jet Cluster

Right Jet Selector handle right (out)
 (*)Right Calf Jetstream diverter left

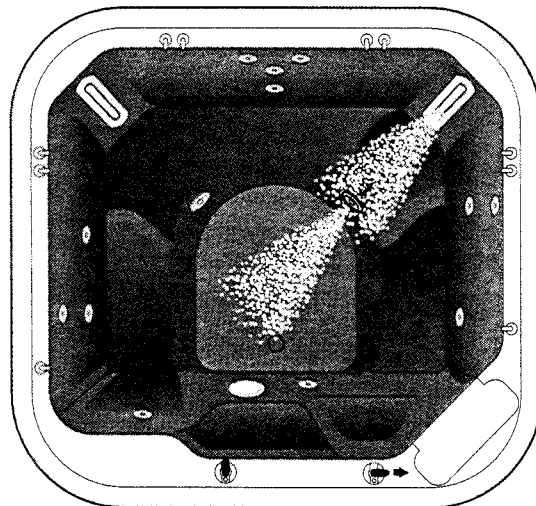

SYSTEM 7: Secondary, Mode II, Right Jet Pump
 Jets:
 1 Moto-Massage
 1 Calf Jetstream

Right Jet Selector handle right (out)
 (*)Right Calf Jetstream diverter on
 (center position)

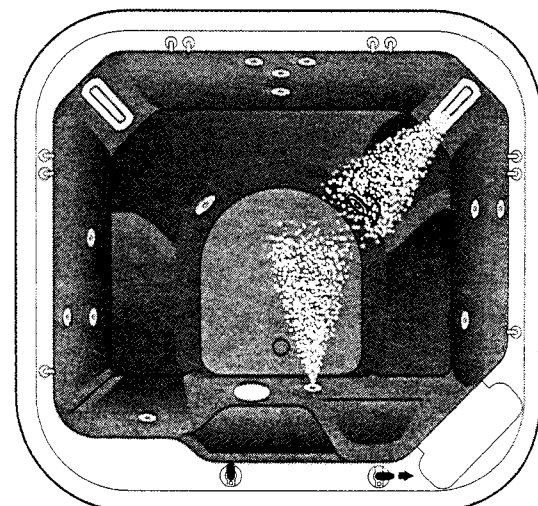

SYSTEM 8: Secondary, Mode III, Right Jet Pump
 Jets:
 1 Moto-Massage
 1 Foot Jetstream

Right Jet Selector handle right (out)
 (*)Right Calf Jetstream diverter right

HIGHLIFE (MODEL K) JET SYSTEM MENU

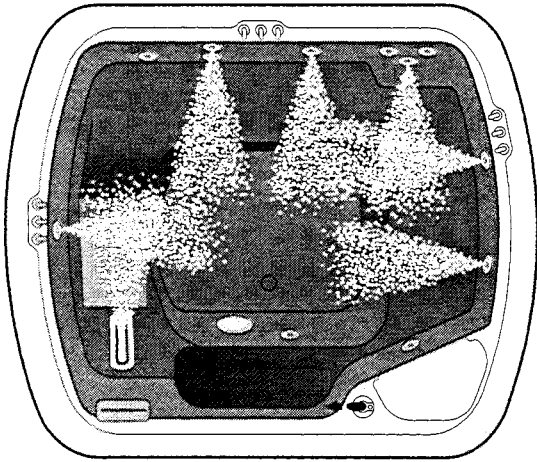

CONTROL PANEL

SYSTEM 1: Primary Mode
 Jets: 1 Moto-Massage
 5 Fixed Jets
 2 Fixed, Stacked on back wall

Jet Selector handle left (in)

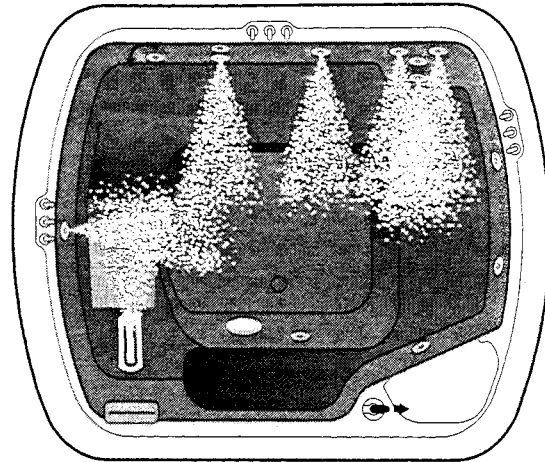

SYSTEM 2: Secondary, Mode I
 Jets: 1 Moto-Massage
 3 Fixed Jets
 3 Jet Cluster

Jet Selector handle right (out)
 (*)Jetstream diverter left

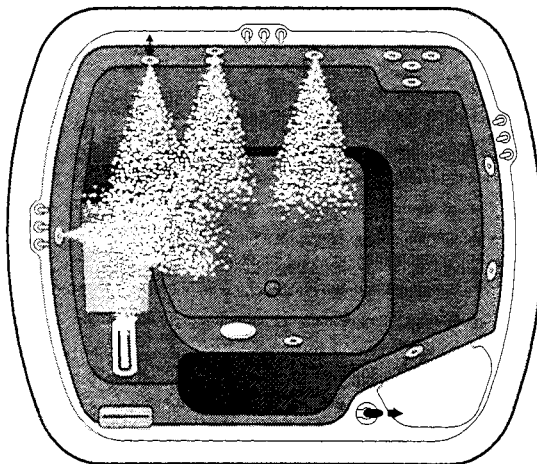

SYSTEM 3: Secondary, Mode II
 Jets: 1 Moto-Massage
 1 Jetstream on rear wall
 3 Fixed Jets

Jet Selector handle right (out)
 (*)Jetstream diverter on
 (center position)

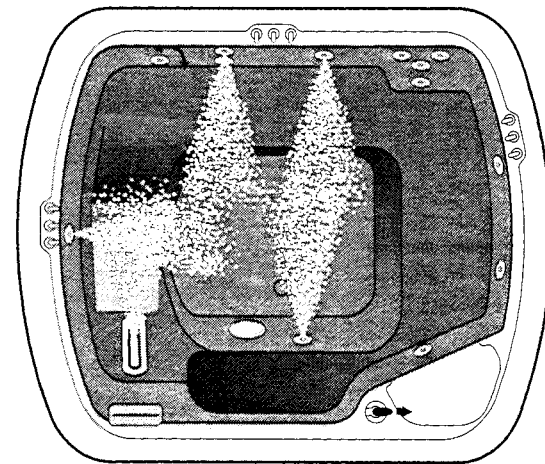

SYSTEM 4: Secondary, Mode III
 Jets: 1 Moto-Massage
 3 Fixed Jets
 1 Jetstream next to light

Jet Selector handle right (out)
 (*)Jetstream diverter right

CLASSIC (MODEL F) JET SYSTEM MENU

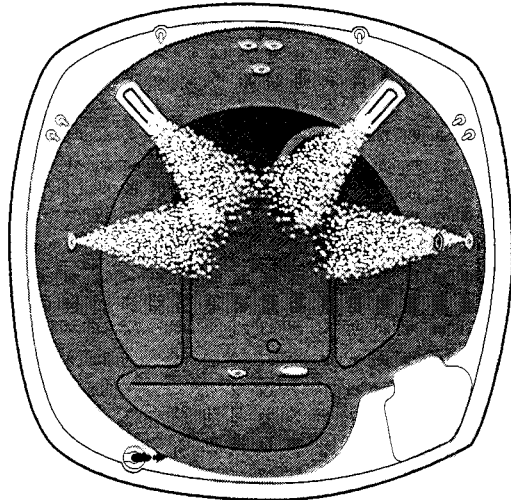

CONTROL PANEL

SYSTEM 1: Primary Mode
 Jets:
 2 Moto-Massage Jets
 1 Fixed Jet on left wall
 2 Fixed, Stacked on right wall

Jet Selector handle right (in)

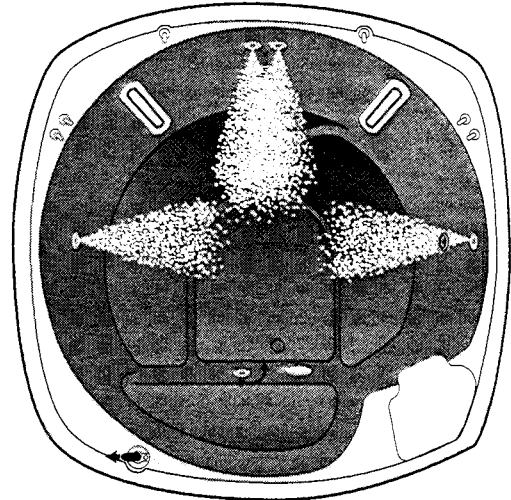

SYSTEM 2: Secondary, Mode I
 Jets:
 3 Jet Cluster
 2 Fixed, Stacked on right wall
 1 Fixed Jet on left wall

Jet Selector handle left (out)
 (*)Jetstream diverter left

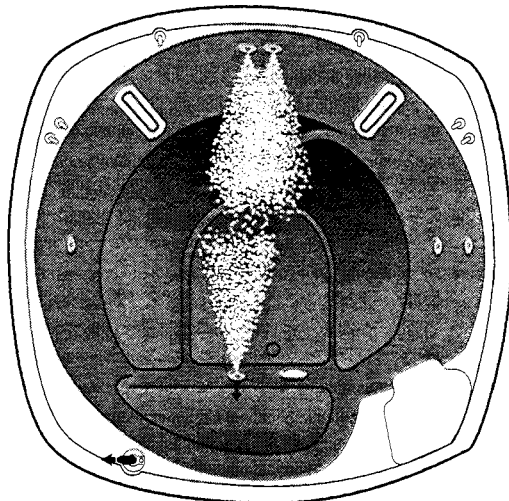

SYSTEM 3: Secondary, Mode II
 Jets:
 3 Jet Cluster
 1 Jetstream

Jet Selector handle left (out)
 (*)Jetstream diverter on
 (center position)

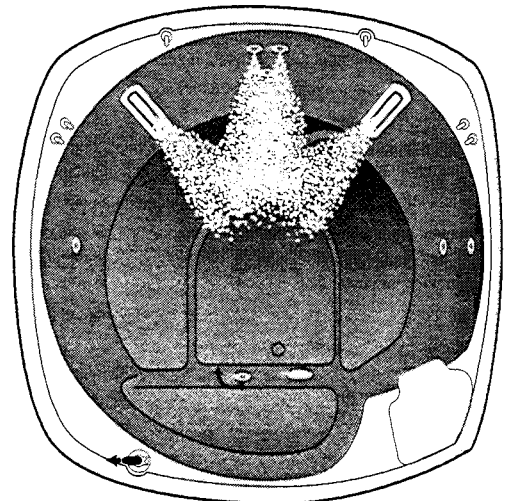

SYSTEM 4: Secondary, Mode III
 Jets:
 2 Moto-Massage
 3 Jet Cluster

Jet Selector handle left (out)
 (*)Jetstream diverter right

SOVEREIGN (MODEL I) JET SYSTEM MENU

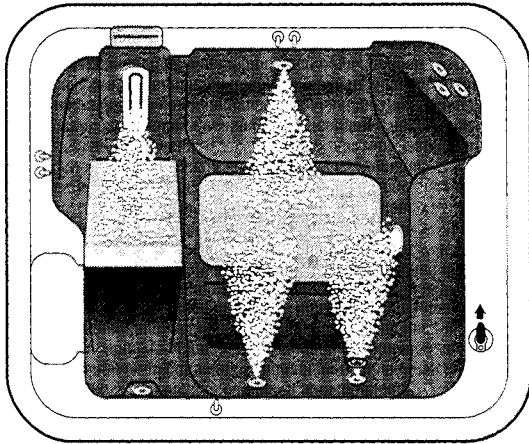

CONTROL PANEL

SYSTEM 1: Primary Mode
 Jets:
 1 Moto-Massage
 2 Fixed, Stacked on left wall
 1 Fixed Jet on left wall
 1 Fixed Jet on right wall

Jet Selector handle right (in)

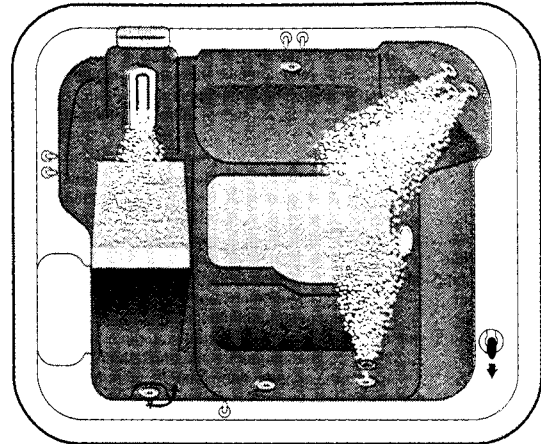

SYSTEM 2: Secondary, Mode I
 Jets:
 1 Moto-Massage
 3 Jet Cluster
 2 Fixed, Stacked on left

Jet Selector handle left (out)
 (*)Jetstream diverter left

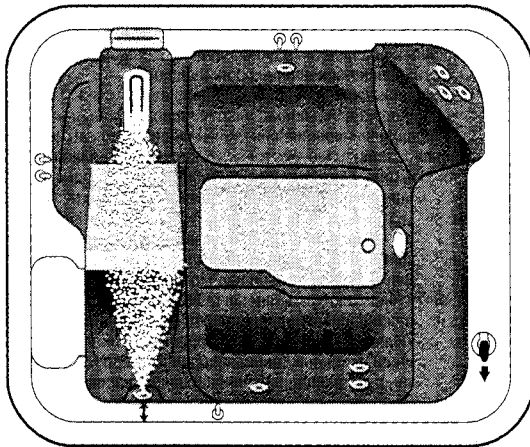

SYSTEM 3: Secondary, Mode II
 Jets:
 1 Moto-Massage
 1 Jetstream

Jet Selector handle left (out)
 (*)Jetstream diverter on
 (center position)

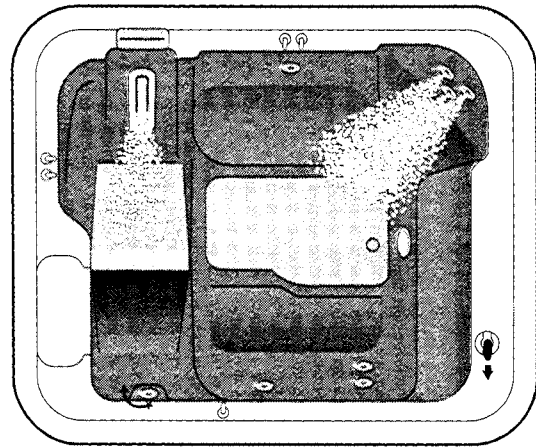

SYSTEM 4: Secondary, Mode III
 Jets:
 1 Moto-Massage
 3 Jet Cluster

Jet Selector handle left (out)
 (*)Jetstream diverter right

PRODIGY (MODEL H) JET SYSTEM MENU

CONTROL PANEL

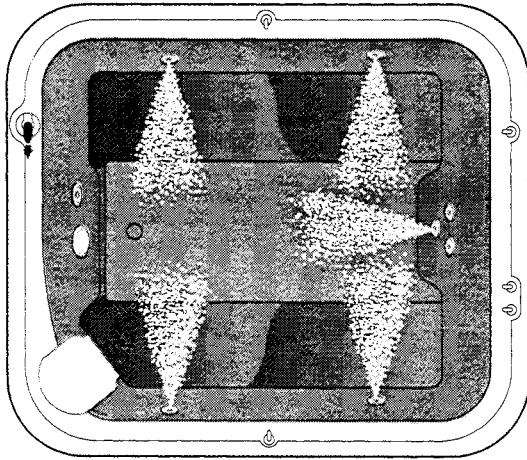

SYSTEM 1: Primary Mode
 Jets:
 2 Fixed Jets on right wall
 2 Fixed Jets on left wall
 1 Fixed Jet, bottom of 3 Jet Cluster

Jet Selector handle right (in)

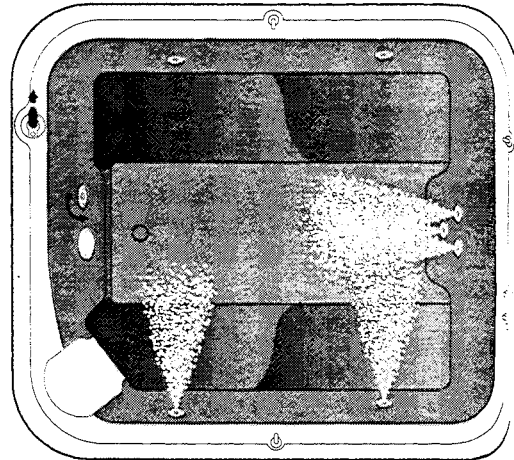

SYSTEM 2: Secondary, Mode I
 Jets:
 2 Fixed Jets on right wall
 3 Jet Cluster

Jet Selector handle left (out)
 (*)Jetstream diverter left

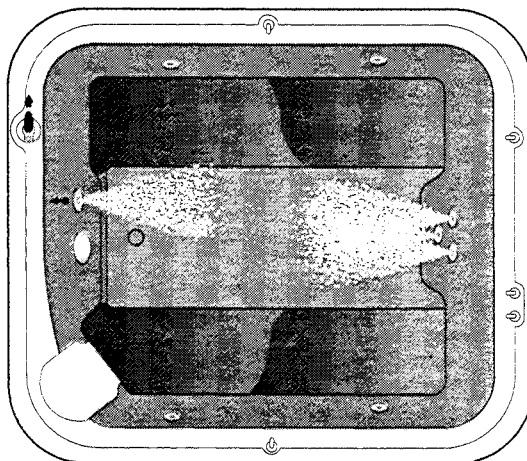

SYSTEM 3: Secondary, Mode II
 Jets:
 3 Jet Cluster
 1 Jetstream

Jet Selector handle left (out)
 (*)Jetstream diverter on
 (center position)

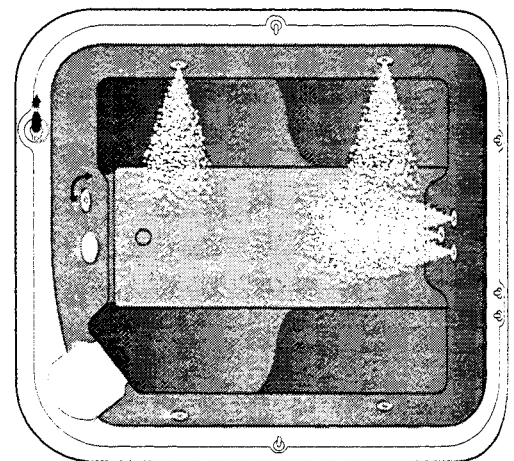

SYSTEM 4: Secondary, Mode III
 Jets:
 2 Fixed Jets on left wall
 3 Jet Cluster on back wall

Jet Selector handle left (out)
 (*)Jetstream diverter right

JETSETTER (MODEL J) JET SYSTEM MENU

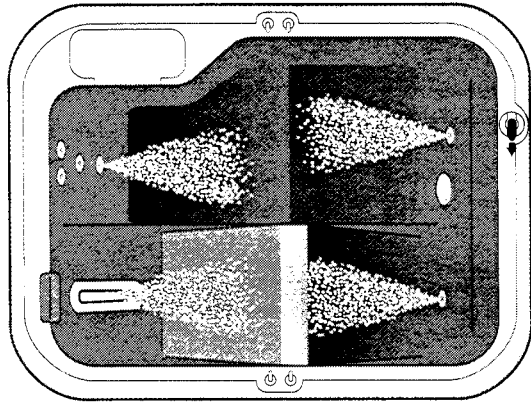

CONTROL PANEL

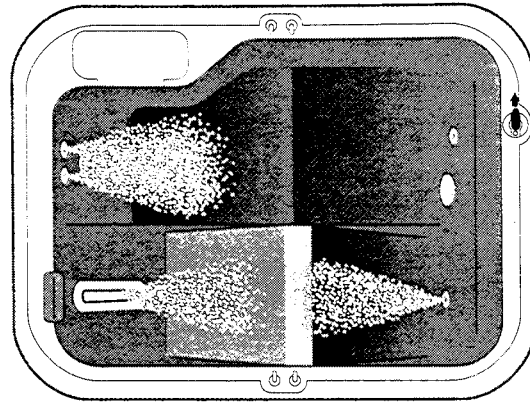

SYSTEM 1: Primary Mode
 Jets: 1 Moto-Massage Jet
 1 Fixed Jet, Bottom of Cluster
 2 Fixed on front wall

Jet Selector handle left (in)

SYSTEM 2: Secondary Mode
 Jets: 1 Moto-Massage Jet
 1 Fixed Jet at end
 of Moto-Massage lounge
 3 Jet Cluster

Jet Selector handle right (out)

CONTROL PANEL

HIGHLIFE
 CLASSIC
 SOVEREIGN
 PRODIGY
 JETSETTER

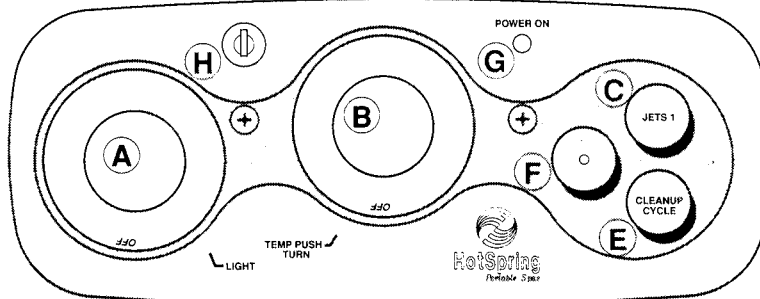

GRANDEE

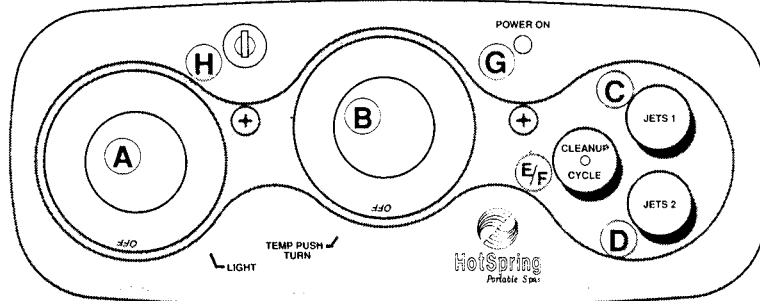

A - Light Control
 B - Temperature Control
 C - Jets 1 button
 D - Jets 2 button (GRANDEE model only)

E - Cleanup Cycle button
 F - Cleanup Cycle indicator
 G - Power-On Indicator
 H - Control Panel Lock

CONTROL PANEL

- A. **LIGHT CONTROL:** Use this dial to turn on and control the intensity of the spa light.
- B. **LOCK:** HOT SPRING Spa control panels are equipped with a hidden, tamper-proof locking mechanism. To engage the lock, shut off the Jet(s) button (if applicable). If the Clean-up Cycle button has been activated, the jet pump will shut off automatically. Insert the key and turn it counterclockwise to lock the controls.
- C. **TEMP CONTROL:** The Temp control is used to regulate the water temperature of the spa. To bring the spa water up to a temperature of approximately 100 degrees F., push in the dial and turn it to the number "5." As stated in the Start-up Procedures, a water temperature not exceeding 104 degrees F. can be achieved by setting the "Temp" dial not higher than number "7." Please note, the numbers around the dial are reference points to be used during temperature adjustments. They do not reflect the actual water temperature of the spa. Once the dial has been set and the water temperature stabilized, the water will remain within one degree of your selected temperature.
Before entering the spa, the user should always check the water temperature with an accurate thermometer or test the temperature with their hand to be sure it's comfortable.
- D. **POWER-ON INDICATOR:** For your convenience, the control panel incorporates a power-on indicator which, in addition to showing the spa has power to it, provides a diagnostic function as well. The indicator light will begin blinking if the heater high-limit thermostat has tripped. If the indicator is blinking, refer to the Troubleshooting Guide in this manual to identify and correct the cause. The indicator will stop blinking once the problem has been corrected.
- E. **CLEAN-UP CYCLE INDICATOR:** On all HOT SPRING Spa models, the indicator light will illuminate when the "Clean-up Cycle" button has been activated. Because the GRANDEE has a "Jets" button for each of its two jet pumps, the clean-up cycle indicator light has been incorporated into its Clean-up Cycle button.
- F. **CLEAN-UP CYCLE:** The jet button labeled "Clean-up Cycle" will activate a 10-minute timer mode for convenient water maintenance. To utilize the timer

feature, simply fold back the spa cover, push the Clean-up Cycle button to activate the jet pump, add the required amount of spa water chemicals into the filter compartment, then close and secure the spa cover. The hydrotherapy jet pump will automatically shut off after 10 minutes.

The 10-minute timer feature is also a convenient method to time your spa use. The accuracy of the timer is: 10 minutes \pm 0 to 1 minute.

OPERATION NOTES: 1) The Clean-up Cycle can be turned off at any time by pushing the button a second time or it can be overridden by pushing the "JETS 1" button; 2) The Clean-up Cycle on the GRANDEE will only activate the left jet pump. Pushing the button while both jet pumps are operating will turn off the right pump (JETS 2) and switch the left pump (JETS 1) to the 10-minute timer mode.

G. **JETS:** On all HOT SPRING Spas except for the GRANDEE model, the jet button located at the top right side of the control panel is used to activate the hydrotherapy jet pump continuously. On the GRANDEE, this button is used to activate the left jet pump. The button labeled "JETS 2" is used to activate the right jet pump. To activate the switch, simply push the "Jets" button once; pushing it a second time will deactivate the pump circuit (shut off the jet pump).

OPERATION NOTE: Pushing the Jets button (or either Jets button on the GRANDEE) at any time during a Clean-up Cycle mode will override the 10-minute timer.

G.F.C.I.

The Ground Fault Circuit Interrupter is a safety device that is designed to detect as little as (5 \pm 1) milliamps of electrical current leakage to ground.

Watkins Manufacturing recommends that the G.F.C.I. be tested monthly to ensure it is functioning correctly. With the spa connected to the power supply, push the "test" button. The spa should stop operating and the G.F.C.I. L.E.D. indicator light will go out. Next, wait 30 seconds, then reset the G.F.C.I. by pushing the "Reset" button. The spa will now operate normally and the L.E.D. indicator

will become lit to indicate power has been restored. If the interrupter does not perform in this manner, a ground current is flowing indicating the possibility of an electric shock. Disconnect the spa from the power supply until the fault has been identified and corrected by an authorized service technician.

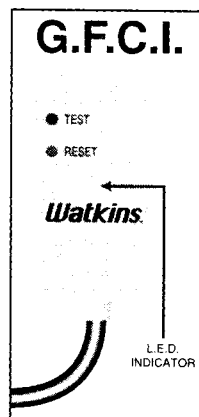

LIGHT

All HOT SPRING Portable Spas come equipped with a dimmer controlled light to enhance nighttime use. The light uses a standard 100 watt outdoor PAR lamp. Should you wish to change the lamp, follow these simple steps:

1. Disconnect the spa from the power supply. On 115 Volt models remove the power cord (plug) from the house receptacle and on 230 Volt models trip the two G.F.C.I. breakers in the subpanel.
2. Remove the screws securing the equipment access door; remove the door on wood skirted spa models or raise and secure the door on the CLASSIC model.
3. Locate the lamp which is secured into the heat guard assembly. Carefully lift the back of the lamp (with the socket assembly still attached) until the bottom of the lamp lens snaps out of the retainer.
4. Carefully pull the lamp, socket and cable assembly to the front of the equipment compartment.

IMPORTANT: Hold the lamp socket firmly with one hand while removing the lamp. Turning the lamp socket rather than the lamp for removal may cause damage to the lamp cable.

5. Replace with a 75 or 100 watt lamp.

WARNING: When installing a new lamp, it must be snapped firmly into the lamp heatguard. Failure to install the lamp into the heatguard may result in damage to the spa and/or equipment.

To install the lamp into the heatguard:

6. Engage the lamp on two of the three "bulb retainers".
7. Carefully snap the lamp into the third bulb retainer. This will hold the lamp firmly in the heat guard and at the correct distance from the light lens.
8. Replace or close the equipment access door and secure it in place to restore power to the spa. (Reconnect the power cord on 115 Volt models or "Reset" the G.F.C.I. breakers on 230 Volt models.)

IMPORTANT: Do Not Use A Light Bulb In Excess of 100 Watts!

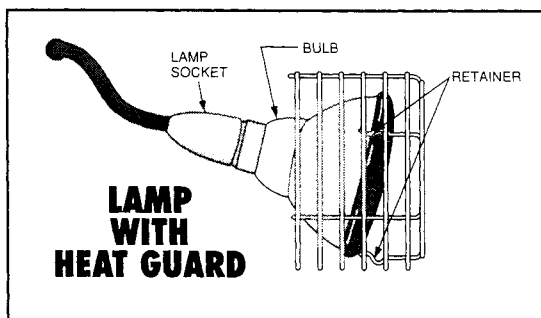

SUMMER MODE (115 Volt Models only)

Your 115 volt HOT SPRING Portable Spa is equipped with a "Summer Mode" switch. The Summer Mode switch can be activated during the extremely hot summer months if it becomes difficult to maintain water temperatures at the desired thermostatic setting. Upon switching to the ON mode, the circulation pump (which can add heat to the water through normal operation), heater and ozone (if installed) will immediately shut down for the next eight hours. Following this eight hour period, the circulation pump, heater and ozone will automatically re-start and will operate normally for the next sixteen hours. The circulation pump will continue to turn off for the same eight hour period every day that the switch remains in the ON position. In this way, the amount of heat transferred to the spa water will be minimized. When the outside temperatures begin to cool, the Summer Mode switch should be turned to the OFF position. This is the efficient, 24 hour circulation mode which keeps the heater operation and operating costs to a minimum during colder/heavier usage months.

NOTE: The Summer Mode will not lower the spa's water temperature below the ambient air temperature.

To activate the Summer Mode, simply refer to the following steps:

1. Turn the Temperature control all the way down.
2. Remove the screws securing the equipment compartment door. On wood skirted models, remove the door completely. On Classic model spas, lift and prop the door in the open position.
3. Locate the black metal control box.
4. On the left hand side of the control box above the three electrical white plugs is the Summer Mode toggle switch.
5. Activate the Summer Mode by moving the switch to the ON or up position.
6. Replace and secure the equipment compartment door.

The Summer Mode must be deactivated when cooler temperatures return. To do this simply repeat the steps above to access the Summer Mode switch and then move the switch from the ON or up position to the OFF or down position.

WARNING: Failure to deactivate the Summer Mode when the temperature drops below 32 degrees F. will result in freezing of the spa. Damage resulting from this is not covered under the terms of the warranty.

V. SPA CARE AND MAINTENANCE

GENERAL INFORMATION

Your HOT SPRING Spa is manufactured from the highest quality, most durable materials available. Even so, Watkins Manufacturing Corporation recommends that a spa care and maintenance program be followed to increase your comfort and maintain the spa's reliability. The spa care and maintenance program you develop will ultimately determine how long your spa or its individual components will last. The following maintenance section when adhered to, will help you protect your investment.

DRAINING THE WATER

Detergent residues from bathing suits as well as soap film from your body may gradually accumulate in the water. Normally, in two to three months the water will become sudsy and should be replaced.

NOTE: Showering without using soap prior to entering the spa or only using a "rinse" cycle when laundering your bathing suit will help to avoid detergent residue in the spa water.

To drain your spa:

1. Disconnect the spa from the power supply by one of the two following methods:

115 Volt Models- Disconnect the power cord from the house receptacle. Set the power cord in an elevated position so as not to allow water to enter the G.F.C.I. plug housing during draining of the spa.

230 Volt Models- Trip all of the G.F.C.I. breakers located in the subpanel.

NOTE: Disconnect power to the FRESH WATER I Ozone Purification System (if applicable).

2. Remove the screws from the equipment access door; remove the door on the wood skirted spa models or raise and secure the door on the CLASSIC model. Locate the main drain valve for the spa and remove the drain cap. Attach the inlet of a garden hose to the drain valve (to avoid flooding the foundation surrounding the spa) and route the outlet of the hose to an appropriate draining area.

IMPORTANT: If your spa is equipped with The Tip Top cover, it should be open during draining of the spa.

NOTE: Spa water with a high sanitizer level may harm plants and grass.

3. Open the valve by turning the knob counterclockwise and the spa will drain by gravitational flow.

IMPORTANT: All HOT SPRING Spa models will drain almost completely through the main drain valve. This includes the equipmentment such as hydrotherapy jet pump, and heating system. Any water remaining within the plumbing or equipment after draining will only need to be removed if the spa is being "winterized".

4. Allow most of the water to drain through the main drain.
5. Remove threaded cap from secondary drain. This will drain the remaining water (about 1 gal) from the bleedline system.
6. When empty, inspect the spa shell and clean as required. (Follow Care of the Exterior Finish/ENDUR[®] Spa Shell Instructions.)
7. Close the drain valve and reinstall the drain cap.
8. Reinstall threaded cap onto secondary drain.
9. Replace or close the equipment access door and reposition the screws.
10. Refill the spa BEFORE restoring power to it.

IMPORTANT: Always clean the filter cartridges each time the spa has been drained for cleaning.

FILTER SYSTEM

HOT SPRING Spas are equipped with balanced filtration for the jet pump system and a dedicated filter cartridge for the 24-hour circulation/filtration system. Balanced filtration means one square foot of filter media is provided for each gallon of water passing through it each minute. Spa models with a Wavemaster 5000 or 7000 jet pump are equipped with two 30-square-foot filter cartridges (the GRANDEE model is equipped with two cartridges for each jet pump). The HIGHLIFE, which is equipped with a Wavemaster 9000 jet pump, incorporates three filter cartridges (90 square feet total) to balance its 90 gpm water volume. Each filter cartridge is secured vertically in the filter compartment by a filter standpipe and retainer.

As with any water filtering system, the filter cartridges may become clogged with particles or with calcification that will result in reduced water flow. In your HOT SPRING Spa, it is important to maintain a clean, unobstructed filtering system. This not only provides the maximum performance from the hydrotherapy jets, but allows the 24 hour filtration system to function effectively. Watkins Manufacturing Corporation recommends the filter cartridges be cleaned (either spraying clean with water or soaking to dissolve minerals) EVERY MONTH!

SERVICE NOTE: Periodically rotating the placement of the filter cartridges within the filter compartment will help to extend their service life.

WARNING: Failure to maintain the cartridges in a clean, unobstructed manner will result in reduced water flow through the heater assembly which may cause the Heater High Limit Thermostat to "trip". If this high limit "trip" occurs during sub-freezing temperatures and goes unnoticed, the spa water may freeze. Any damage to the spa (due to freezing) caused as a result of poor maintenance (stated under misuse or abuse of the HOT SPRING Spa Limited Warranty), will not be covered by your spa warranty.

DANGER!: To reduce the risk of injury to persons using the spa, DO NOT remove the suction fittings (filter standpipes) located in the filter compartment.

FILTER CARTRIDGE REMOVAL & INSTALLATION INSTRUCTIONS (All Models)

1. Remove and carefully set aside the filter compartment cover.
2. Remove any floating items from within the filter compartment.
3. Turn the filter retainer handle (located on the top of the filter cartridge) counterclockwise until the retainer can be removed from the filter standpipe.
4. Remove the filter retainer and cartridge.

SERVICE NOTE: Do not remove the filter standpipe when the spa is full of water. Debris may find its way into the internal plumbing which may result in blockage of the hydrotherapy or continuous filtration system.

5. To reinstall the filter cartridge, reverse the order in which it was removed. Do Not Overtighten!

FILTER CARTRIDGE CLEANING INSTRUCTIONS

1. Place the filter cartridge on a clean foundation and spray each cartridge clean using a garden hose. It may be necessary to rotate the cartridge while spraying so as to thoroughly remove any debris lodged between the filter pleats.
2. After allowing it to dry, inspect the filter cartridges for calcium deposits (scaling) or an oil film.

SERVICE NOTE: Extremely hard water will cause a rapid buildup of minerals on the cartridge. Additionally, the use of oil-base spa water scents (and body oils) may coat the filter cartridge. The use of a garden hose will not remove either the mineral deposits or the oil film. A filter cartridge cleaner to soak the cartridges in is available from your HOT SPRING Spa dealer.

WARNING: Do not use the spa with the filter cartridges or filter standpipe removed!

CARE OF THE SPA PILLOWS

The spa pillows used on the HIGHLIFE, SOVEREIGN and JETSETTER Spa models will provide years of comfort if treated with care. They have been positioned above the water level to minimize the bleaching effects of chlorinated water and other spa water chemicals. To extend their life, whenever the spa shell is being cleaned, the spa pillows should be removed and cleaned. Body oils can be removed with a mild soap and water solution. ALWAYS rinse off the spa pillows thoroughly to remove any soap residue. The pillows can be conditioned with Watkins Cover Shield after cleaning. If the spa is not going to be used for a long period of time (during a vacation or if the spa is winterized), or when the spa water is being super-chlorinated, the spa pillows should be removed until the next use of the spa. To remove the spa pillows:

1. Fold back the spa cover to access the spa pillows.
2. Carefully lift one end of the pillow away from the spa shell.

3. Continue lifting one end until both pillow retainers are released from the pillow.

IMPORTANT: Just pulling the pillow straight up and out of the shell recess will eventually damage the pillow. This abuse is not covered under warranty.

4. To reinstall the spa pillow, carefully bend the pillow slightly to allow one of the pillow retainers to slip into the recess in the back of the pillow.
5. Keeping the pillow slightly bent, slide the remaining pillow retainer into the recess in the back of the pillow.
6. After the second pillow retainer is in place, press the pillow down into pillow recess in the spa shell.

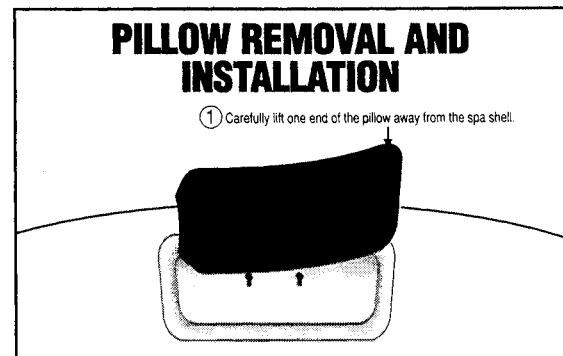

CARE OF THE EXTERIOR FINISH ENDUROL® Spa Shell

Your HOT SPRING Spa has a high quality ENDUROL thermoplastic shell. Stains and dirt generally will not adhere to this surface. Cleaning of the surface should be done with a non-abrasive, non-sudsing cleaner. Your dealer stocks Spa Shine, a surface cleaner and spa polish formulated specifically for the HOT SPRING EnduroL spa shell. Baking soda can also be used for minor surface cleaning at the water level. The use of a soft rag or a nylon scrubber should easily remove most dirt buildups.

SERVICE NOTES:

1. Iron and copper can stain the ENDUROL spa shell if allowed to go unchecked. Your HOT SPRING Spa dealer stocks a Stain and Scale Inhibitor to use if your spa water has high concentrations of dissolved minerals. Watkins Spa Shine can be used after surface cleaning to "shine" the ENDUROL spa shell. Do not use any cleaners on the vinyl spa pillow.
2. Use care not to get baking soda on the redwood spa skirts as discoloration may occur.
3. The use of alcohol or any household cleaners other than those listed to clean the spa shell surface are NOT recommended.

IMPORTANT: Always thoroughly rinse off any spa shell cleaning agent. Some surface cleaners contain eye and skin irritants. Keep all cleaners out of reach of children and use care when applying.

Redwood Spa Skirt

The spa skirts on HOT SPRING Spas are constructed from the finest quality, clear all-heart redwood. During the manufacturing process of the spa, the redwood skirts are sealed with a lightly tinted stain for protection and to enhance their beauty. Like all wood products, prolonged exposure to outdoor weather conditions will cause the redwood skirts to discolor or dry out. A good quality, natural color, oil-based **wood stain** should be applied to the redwood skirts twice a year or as needed to keep the skirts looking new. Do not use wood sealers or wood furniture-type oils (tung, teak or lemon) to seal the skirts as they will cause the redwood to become black in appearance. Discoloration or aging of the wood skirts is considered natural and is not covered by the seven-year surface warranty.

NOTE: Your HOT SPRING Spa dealer may stock the Original Factory Finish or may suggest another spa skirt stain product. Always test a small area (only 1 or 2 vertical corner boards are recommended) of your spa skirt for stain and wood compatibility if applying a non-recommended stain.

CARE OF THE THERMAL COVER "Vinyl" Thermal Cover

The vinyl thermal spa cover is an attractive, durable foam insulation product. Monthly cleaning and conditioning is recommended to maintain its beauty.

To clean and condition the vinyl cover:

1. Remove the cover from the spa and gently lean it against a wall or fence.
2. With a garden hose, spray the cover to rinse away and loosen dirt or debris.
3. Using a large sponge and/or a soft bristle brush, and using a very mild soap solution (1 teaspoon dishwashing liquid with 2 gallons water) or baking soda, scrub the vinyl in a circular motion. Use care not to let the vinyl dry (with a soap film on it) before it can be rinsed clean.

IMPORTANT: To avoid soap getting into the spa water or baking soda getting on the redwood skirt (which may cause black spots or streaks on the redwood), the spa cover should not be on the spa during cleaning.

4. Scrub the perimeter and side flaps of the cover. Rinse clean.
5. Be sure to rinse off the bottom of the cover (use no soap), and wipe it clean with a dry rag.
6. To condition the vinyl cover after cleaning, apply a thin film of HOT SPRING Cover Shield to the vinyl surface and buff to a high lustre.

SERVICE NOTE: To remove tree sap, use lighter fluid (not charcoal lighter but the kind used in cigarette lighters). Use sparingly, and rinse with a saddle soap solution immediately afterwards and wipe dry.

IMPORTANT REMINDERS:

- **DO** remove snow buildup to avoid breakage to the foam core.
- **DO** lock cover straps to secure cover to the spa when spa is not in use.
- **DO NOT** drag or lift the spa cover using either the flaps or the tie-down straps.
- **DO NOT** walk, stand, or sit on the foam insulated cover.
- **DO NOT** place any hot items or objects that will magnify or conduct heat on the foam insulated cover; foam core damage will occur.
- **DO NOT** use any chemicals or cleaners except those recommended by Watkins Manufacturing Corporation or its Authorized Sales and Service Dealer.

The Tip Top® Cover

The Tip Top cover is a durable, foam insulation product designed for year-round use. As with the soft vinyl cover, The Tip Top cover will retain its beauty if it is maintained correctly. This includes monthly cleaning, periodic polishing, and preventive maintenance during the winter.

WARNING: The Tip Top Cover is a manual safety cover that meets or exceeds all prevailing requirements of ASTM Standards for spa safety covers when installed and used correctly as of the date of manufacture. Non-secured or improperly secured covers are a hazard. Open cover to its fully open position before and during spa use.

To ensure many seasons of use, the following use and care instructions should be noted:

How To Use The Cover

1. With the tie-down straps unfastened, stand at either the left or right front corner of the spa.
2. Place one hand under the edge of the cover (your right hand if **standing** on the left, your left hand if **standing** at the right front corner).
3. Place your other hand on the bottom pivot arm (the longest arm on the hinge/gas cylinder assembly).
4. While lifting with one hand (the one under the edge of the cover), take a few steps towards the back of the spa. Your second hand can be used to gently push the cover backwards and also to slow it down so it does not hit hard on the ground behind the spa.

CAUTION: Use care if opening the cover in high winds. Personnel injury or cover damage may result if wind blows the cover down before the cover lock assembly is fastened.

NOTE: The cover is designed to open from front to back, do not twist or attempt to use the cover in a way it is not designed.

5. Fasten the cover lock assembly.

To Close The Cover

1. Unfasten the cover lock assembly.
2. Stand on either side of the spa, gently pull down on the cover.

WARNING: Do not close the cover by pulling on the pivot arms; finger entrapment may occur.

3. Fasten the tie-down straps.

Use Of The Tip Top Cover In Winter

Though The Tip Top cover is structurally the strongest spa cover available, it is not designed to withstand excessive or concentrated weights. For that reason sweep off any snow from the top of the cover before it is allowed to accumulate.

NOTE: When using your spa during sub-freezing temperatures, the spa cover may freeze to the ground (when in the open position). If this situation occurs, simply splash a small amount of the hot spa water on the frozen area to break the bond.

SERVICE NOTE: Damage to the cover trim strip or rubber bumpers could occur if you attempt to close the cover if it is frozen to the ground.

Use Of The Tip Top Cover In Winds

In addition to providing user privacy, The Tip Top cover also makes an ideal wind-break. When mounted correctly, it is designed to withstand up to a 35 mph direct wind blast. Regardless, Watkins Manufacturing Corporation recommends the cover lock assembly always be used when the cover is in the open position.

IMPORTANT: The cover lock assembly is a safety device. It is designed to "break away" should the wind factor be excessive or if leverage is placed on the hinge/gas cylinder assembly while the cover is in the upright position (attempting to close the cover while it is still locked, etc.). Should the lock "break away", it will be necessary to refasten the two halves of the lock assembly.

To Clean And Polish The Tip Top Cover

1. Using a garden hose, spray the cover to rinse away any loose dirt or debris.
2. Apply a liquid spa surface cleaner (available from your HOT SPRING Spa dealer) with a cloth or a sponge to the cover surface.

WARNING: Some surface cleaners contain eye and skin irritants. Keep all spa cleaners out of reach of children and use care when applying.

NOTE: If the surface cleaner drips onto the redwood skirt, rinse off with water.

3. After allowing the cleaner to set on the surface for a minute or two to soften the dirt, scrub the cover with a sponge or soft bristle brush.

4. Thoroughly rinse the cover off after cleaning.
5. If you wish to polish the cover, wipe it dry with a soft cloth or towel. Apply HOT SPRING Spa Shine to the Enduroil surface, then buff to a high lustre.
6. Use a damp cloth to remove any dirt from the cover arms, gas cylinder, or the trim strip.

WARNING: The Tip Top cover is not designed to be walked, stood, or sat on; keep children off of the cover! Always lock the cover in place after use.

IMPORTANT: Whenever the spa is not in use, it is essential that the thermal cover be in place. When filled, this ensures effective temperature maintenance and economical operation. When empty, this prevents potential damage to the surface finish of the interior walls which can result from the excessive heat of the sun. This type of damage is specifically excluded from warranty protection. It is recommended that the thermal cover tie-downs always be used to discourage access to the spa by unsupervised children and to minimize heat loss.

VACATION CARE INSTRUCTIONS

If you plan to be away, follow these instructions to ensure the water quality of your spa is maintained:

Short Time Periods (3-5 Days):

1. Adjust the pH by following the instructions outlined in the Water Quality and Maintenance Section.
2. Sanitize the water by following the "super-chlorination" procedures also listed in the Water Quality Section.
3. Lock your thermal cover in place using the tie-downs.
4. Upon your return, sanitize the water (super-chlorinate, if necessary), and balance the pH.

Long Time Periods (5-14 Days):

1. At least one (1) day before you leave, push in and turn the Temperature Control counterclockwise all the way until it stops at the lowest identification mark on the control. This setting should represent an approximate water temperature of 82-85 degrees F.

IMPORTANT NOTE: Spa water oxidizers such as dichlorine maintain their level of effectiveness substantially longer in warm water (80 degrees to 85 degrees F) than in hot water (101 degrees to 104 degrees F).

Prior to leaving:

2. Adjust the pH as required.
3. Sanitize the water by following the SUPER-CHLORINATION procedures.
4. Upon your return, check the level of sanitation of your spa water. If the chlorine test kit reads "0" and you have been gone an extended period of time,

SUPER-CHLORINATE the spa water to ensure all organisms or algae are oxidized. Push in and turn the Temperature Control clockwise to return it to the original setting. The spa water will be safe for you to use once the Free Chlorine Residual has dropped below 5.0 ppm.

NOTE: If you will not be using your spa for an extended period of time (in excess of 12-14 days) and an outside maintenance service (or neighbor) is not available to assist with the water maintenance, draining or winterizing of the spa is recommended.

PREVENTION OF FREEZING

The HOT SPRING Spa has been designed and engineered for year-round use in any climate. In some areas, extremely cold temperatures (below 10 degrees F) combined with strong wind (chill factor) may cause partial freezing of the jet pump (even though the water inside the spa remains at the selected temperature). The energy efficiency of the spa may also decrease during these cold periods as the heater will cycle more frequently. To avoid most problems associated with component freezing, the 24-hour continuous-filtration system has been designed with bleed lines connecting the jet pumps with the heating/filtering system. Thus, as the heating system circulation pump runs continuously, cooling water in the different systems is continually evacuated and replaced by warm spa water. As an additional precaution against partial freezing of some of the components, the equipment compartment door can be insulated with a fiberglass insulation blanket (available from your HOT SPRING Spa dealer). This additional insulation will help to maximize the spa's energy efficiency.

NOTE: When warmer weather returns (approx. 60-70 degrees F), the insulating blanket must be removed to prevent overheating of the jet pump.

Please contact your HOT SPRING Spa dealer for additional information or to order the Insulation Kit.

WINTERIZING

In very cold weather you may not want to venture outside to use your spa. In this case, you may move it to a heated area, or leave it as is until the weather warms. If you do leave the spa unused for a long period of time in severely cold weather, you should drain the spa to avoid accidental freezing due to a power or equipment failure.

Your local authorized dealer can perform the following winterizing steps if you do not wish to attempt them yourself:

1. Disconnect the spa from the power supply by one of the two following methods:

115 Volt Models - Disconnect the power cord from the house receptacle. Set the power cord in an elevated position so as not to allow water to enter the G.F.C.I. plug housing during draining of the spa.

230 Volt Models - Trip all of the G.F.C.I. breakers located in the subpanel.

NOTE: Disconnect power to the FRESH WATER | OzOne Purification System and open the Tip Top Cover (if applicable).

2. Remove the screws from the equipment access door; remove the door from the wood skirted spa models or raise and secure the door on the CLASSIC model.
3. Locate the main drain valve for the spa and remove the drain cap. Attach the inlet of a garden hose to the drain valve and route the outlet of the hose to an appropriate draining area.
4. Open the valve and the spa will drain by gravitational flow.
5. All HOT SPRING Spa models will drain almost completely through the main drain valve. This includes the equipment such as the hydrotherapy jet pump, heater circulation pump, and heating system.
6. Remove the threaded cap from the secondary drain. The remaining water (about 1 gallon) will drain from the bleedline system.
7. Remove the filter cartridges, clean and store the cartridges in a dry place.
8. **IMPORTANT:** Sponge out any residual water from inside the spa and the recesses of the MOTO-MASSAGE and filter compartments. Wipe all surfaces dry.
9. If your spa has a vinyl thermal cover, cover it with a large board to distribute the weight from snow and ice.

SERVICE NOTES:

1. Refer to MOTO-MASSAGE Section for face plate removal instructions.
2. Leave the main drain valve open approximately 1/4 turn during the winterizing months.
3. You may wish to remove the filter standpipe to facilitate draining of the filter compartment.

NOTE: Ensure no debris is present on the floor of the compartment prior to removal of the filter standpipe (large debris may block freeze drain bleed lines if allowed to enter the plumbing lines). When replacing, do not overtighten.

4. To ensure the internal plumbing has drained completely, a wet/dry shop vac can be used to draw any remaining water through the drain.

To Reactivate:

Reinstall the filter cartridges, close the main drain and reinstall the drain cap. Follow the Start-Up Procedures to get your HOT SPRING Spa operational.

IMPORTANT: Always keep spa covered when not in use (empty or full).

VI. WATER QUALITY AND MAINTENANCE

The material in this section is presented in the same order as the recommended maintenance steps. They include:

1. Water Chemistry Basics: Introduction/General Information, Spa Water Testing, Water Chemistry Terminology, Four-Step Spa Start-up Program.
2. Chemical/Water Chemistry: Chemical Safety and Storage, Adding Spa Water Chemicals, Mineral Content-Total Alkalinity/Calcium/pH Control/pH Do's & Don'ts.
3. Sanitation/Chlorine: Sanitation/Chlorine & Sanitation Table, Testing – Free Available Chlorine & Super-Chlorination, Sanitation Level Chart, Sanitizing Do's & Don'ts.
4. Water Purification/Ozone: General Information, Sanitation Level Chart, Questions & Answers.
5. Supplemental Water Maintenance, Troubleshooting Guide.

INTRODUCTION

Just as the care and maintenance of your spa is important to maintaining its value and ensuring trouble-free performance, water quality and maintenance is important for user enjoyment and protection. It is important to note that while at first you may be overwhelmed by the amount of information contained in this section, spa water maintenance actually consists of a four-step, easy-to-develop program.

Once you have had an opportunity to read this section and apply the information during the first 30 days of spa ownership, you will be well on your way to developing a Water Quality and Maintenance Program. It will be based upon your spa use (frequency and duration), user load (number of spa users), rate of contamination (again dealing with number of spa users and frequency), and the beginning mineral content of your tap water. Should you have any questions regarding spa water maintenance that have not been answered in this section, please contact your authorized HOT SPRING Spa dealer.

GENERAL INFORMATION

Safe, comfortable and clean spa water isn't difficult to achieve. However, a total spa water maintenance program is required. This program encompasses not only water circulation and filtration, but also correct spa water chemistry achieved through water sanitation and mineral

balance. Watkins Manufacturing Corporation recommends the following spa sanitation and pH control procedures (based on average spa use in an ideal situation). Additionally, your HOT SPRING Spa dealer is a trained professional who can assist you in developing a start-up and maintenance program based on your "tap water" mineral content and the average user load of your spa. Check with your dealer; many offer in-house water analysis to assist in resolving specific water chemistry problems.

Spa water sanitation is chemically achieved with CHLORINE (Sodium/Dichloro-S-Triazinetrione **or** Sodium Dichloro-Isocyanurate). Mineral balance and pH control are chemically achieved with mineral additives. Filtration is mechanically achieved by pumping water through a filter with tiny pores. Bacteria and viruses are so small they pass right through the filter pores. They must be killed by chemical actions; i.e. chlorine. Both sanitation and filtration are necessary for water clarity. Maintaining the correct pH and mineral balance of the spa water will ensure a long life for the electrical components and reduce spa surface scaling.

IMPORTANT: Your HOT SPRING Spa warranty specifically **excludes** surface or component damage caused by poor water chemistry, the improper use or application of chemicals, the use of non-approved chemicals, or the non-control of pH. In addition, any spa shell, plumbing, electrical system, thermal cover, or other component failure resulting from the addition of any non-approved alternate water sanitation or purification device, heating system or the modification of the original equipment is not covered by your HOT SPRING Spa warranty.

SPA WATER TESTING

An essential part of your spa water maintenance program is the testing of the water for total alkalinity, calcium hardness, pH and chlorine levels. Three types of testing methods are recognized by Watkins Manufacturing. They are:

1. A five-function test kit contains a calibrated test block, DPD tablets for Free Available Chlorine testing, plus reagents for testing pH, total alkalinity and mineral content. When used correctly, a five-function test kit will provide the highest level of accuracy.
2. Three- or four-function test strips are the most convenient method for the testing of Free Available Chlorine, pH, and total alkalinity. If you are using test strips as part of your program, keep in mind that they are susceptible to heat and moisture contamination which will result in inaccurate readings.
3. A two-function test kit containing DPD tablets for testing Free Available Chlorine levels and Phenol Red for testing water pH can also be used. (Test strips will still need to be used for testing total alkalinity and calcium hardness levels.)

NOTE: The use of an OTO test kit is not recommended because it only measures the Total Available Chlorine level (free chlorine residual and combined chlorine).

Testing your spa water should be done daily until user load is established, then test a few times weekly to be sure proper levels are maintained.

A few simple precautions must be taken to ensure maximum efficiency and accurate test data:

- When using the DPD test block method, always take water samples 12"-18" below the water surface. Rinse the test cells before and after each use. Do not dispose of test samples in the spa water.
- When adding drops of reagents into the test block, the bottle must be held vertically and the drops added slowly to insure the correct quantity is administered. Reagents should be replaced at least yearly to maintain the accuracy of the test results.
- When using either a calibrated test block or test strips, test comparisons should be made in natural light.
- Read and carefully follow the directions included with the test kit or test strips to ensure the accuracy of the test results.

WATER CHEMISTRY TERMINOLOGY

The following chemical terms will be used in this Water Quality and Maintenance Section. Understanding their meaning will help you to better understand the water maintenance process.

Bromamines: Compounds formed when bromine combines with nitrogen from body oils, urine, perspiration, etc. Unlike chloramines, bromamines have no pungent odor and are effective sanitizers.

Bromine: A sanitizer in the same chemical family as chlorine. Bromine is commonly used in stick, tablet, or granular form.

NOTE: See #2 in DO's and DON'T's of Spa Water Maintenance for additional information.

Calcium Hardness: The amount of dissolved calcium in spa water. This should be approximately 100-200 ppm. High levels of calcium can cause cloudy water and scaling. Lower levels can harm the equipment.

Chloramines: Compounds formed when chlorine combines with nitrogen from body oils, urine, perspiration, etc. Chloramines can cause eye irritation as well as strong odors. Unlike bromamines, chloramines are very weak sanitizers.

Chlorine: An efficient sanitizing chemical for spas. Watkins Manufacturing Corporation recommends the use of "Sodium Dichlor" type granulated chlorine for sanitizing the water. This type is preferred as it is totally soluble and nearly pH neutral.

Chlorine (or Bromine) Residual: The amount of chlorine or bromine remaining after chlorine or bromine demand has been satisfied. This residual is, therefore, the amount of the sanitizer which is chemically available (FREE CHLORINE) to kill bacteria and algae.

DPD: The preferred reagent used in test kits to measure and indicate Free Available Chlorine.

Halogen: Any of the five elements; fluorine, chlorine, bromine, iodine and astatine.

ORP: Oxidation Reduction Potential; the combined value of oxidizers in spa water such as chlorine and ozone (measured in millivolts). The recommended ORP level for spa water is 650. Recommended testing method is with an electronic REDOX potential value tester.

NOTE: Even though ORP testing is the recognized method for commercial spas and pools and water treatment facilities, it is not practical for the homeowner because of the number of variables affecting the accuracy of the measurement device. A DPD test kit which measures a sanitizer's residual is always recommended.

OTO: A test reagent used to measure total chlorine in spa water. OTO can't distinguish between Free Available Chlorine and Combined Chlorine, so it is less desirable than DPD.

Ozone: Ozone is a powerful oxidizing agent and disinfectant which is produced in nature or artificially by man. Ozone forms no by-product such as chloramines (ozone actually oxidizes chloramines) and will not alter the spa water's pH.

pH: The measure of acidity and alkalinity. The recommended pH for spa water is 7.4 to 7.6. Below 7.0 (considered neutral), the spa water is acidic and can damage the heating system. Above 7.8 the water is too alkaline and can result in cloudy water and scale formation on the spa shell and heater.

ppm: An abbreviation for "parts per million," the accepted measurement of chemical concentration in spa water.

Phenol Red: A chemical reagent used in testing for pH.

Reagent: A chemical material in liquid, powder or tablet form for use in chemical testing.

Scale: Rough calcium bearing deposits that can coat spa surfaces, heaters or plumbing lines, and clog filters. Generally, scaling is caused by mineral content combined with high pH and enhanced by hot water.

Super-chlorination: Also known as "shock treatment." A super-chlorination is a process of adding significant doses of a quick dissolving sanitizer ("dichlor" is recommended) to oxidize non-filterable organic waste and to remove chloramines and bromamines.

Total Alkalinity: The amount of bicarbonates, carbonates, and hydroxides present in spa water. Proper total alkalinity is important for pH control. If the TA is too high, the pH is difficult to adjust; if it is too low, the pH will be difficult to hold at the proper level. The desired range of TA in spa water is 125 to 150 ppm.

FOUR-STEP, SPA START-UP & MAINTENANCE PROGRAM

Watkins Manufacturing Corporation recommends a four-step, spa start-up and maintenance program be followed to ensure the proper total alkalinity, calcium hardness, pH and sanitizer levels are maintained. Following these steps in the proper sequence will save you time and frustration.

Step 1: Measure and adjust Total Alkalinity (TA). The ideal range is between 125-150 parts per million (ppm). If the total alkalinity is too high, it can be reduced by using sodium bisulfate. If the alkalinity is too low, it can be increased by adding sodium bicarbonate. Once the TA is within the recommended range, proceed to the next step.

Step 2: Determine Calcium Hardness (CH) which should be between 100-200 ppm. If the test kit/test strip reading indicates it is either too high or low, it should be corrected before proceeding to Step 3. If the water CH is too low (also referred to as soft), calcium hardness increaser can be added to the water to increase the ppm reading. If the water is too high (referred to as hard), it can be corrected by: 1) dilution – a mixture of 75% soft and 25% hard water can be added to attain a reading in the correct range; 2) if soft water is not available or practical for you, stain and scale control should be added to the spa water.

Step 3: Measure and establish the proper pH. The correct range for pH is between 7.4 and 7.6. If the reading is too high, the pH can be lowered by using sodium bisulfate; if it is too low, it can be increased with sodium carbonate.

Step 4: Watkins recommends granulated Sodium Dichlor (chlorine) for sanitizing the spa water. Granulated chlorine, as well as all other spa chemicals, should always be added into the filter compartment with the jets running (Clean-up Cycle activated).

Each time the spa is drained and refilled, the spa water should be "shocked" with sufficient amounts of non-chlorine shock (potassium monopersulfate) or "super-chlorinated" to a reading of 10 ppm. Once super-chlorinated, you should wait until the chlorine reading drops to 5 ppm or below before entering the spa. Chlorine is to be added daily in accordance with the Sanitation Chart on page 40 to maintain a reading of 3.0-5.0 ppm Free Available Chlorine.

If your spa is equipped with a Fresh Water Ozone System, refer to the chart on page 42 for recommended levels.

IMPORTANT: Your HOT SPRING Spa warranty specifically **excludes** surface or component damage caused by poor water chemistry, the improper use or application of chemicals, the use of non-approved chemicals, or the non-control of pH.

CHEMICAL SAFETY AND STORAGE

When using chemicals, read labels carefully and follow directions precisely. Though chemicals protect you and your spa when used correctly, they may be hazardous in a concentrated form. Observe these guidelines:

1. Accurately measure and use the exact quantities specified, never more. Do not overdose.
2. Handle all containers with care. Store in a cool, dry, well ventilated place.
3. Always keep chemical containers closed when not in use. Replace caps on proper containers.
4. Allow only a responsible person to handle spa chemicals. Keep them out of the reach of children.
5. Don't inhale fumes or let chemicals come in contact with your eyes, nose or mouth. Wash your hands after use.
6. Follow the emergency advice on the product label in case of accidental contact, or if the chemical is swallowed. Call a doctor or local Poison Control Center. If a doctor is needed, take the product container along so that the substance can be identified.
7. Don't let chemicals get on surrounding surfaces or landscaping. Don't use a vacuum cleaner to clean up chemical spills.
8. Don't smoke around chemicals. Some fumes can be highly flammable.

ADDING SPA WATER CHEMICALS

IMPORTANT: ALL SPA WATER CHEMICALS MUST ALWAYS BE ADDED DIRECTLY INTO THE FILTER COMPARTMENT WHILE THE HYDROTHERAPY JET PUMP IS OPERATING.

This includes granulated Dichlor, granulated pH Increase or Decrease, granulated Total Alkalinity Increaser, liquid Stain and Scale Inhibitor, liquid De-Foamer, and any other type of approved spa water chemical.

To Administer Spa Water Chemicals:

1. Fold back the thermal cover; carefully remove and set aside the filter compartment cover.
2. Push the button labeled "Clean-up Cycle" to get the hydrotherapy jet pump operational.
3. Carefully measure the recommended amount of spa water chemical and slowly pour it into the filter compartment (Refer to the Sanitation Table for dichlor amounts; follow the directions on the container for the recommended amounts for other approved spa chemicals.) Use care not to splash chemicals on your hands, in your eyes or on the spa shell surface.

- Replace the filter compartment cover, close and secure the thermal cover. The hydrotherapy jet pump will automatically shut off after 10 minutes thus completing the application procedure.

NOTE: Prior to walking away from the operating spa, glance at the Clean-up Cycle indicator and ensure the light is on.

IMPORTANT "SUPER-CHLORINATION/SHOCK TREATMENT" NOTE: When administering a super-chlorination treatment to your spa water, it is advisable to remove the spa pillows (if applicable) and open the thermal cover at least half way to allow the chlorine gas to vent off. This venting is extremely important on spas equipped with The Tip Top cover because of their almost perfect sealing capability. The high concentration of trapped chlorine gas which may exist as a result of super-chlorination (not daily sanitation) may eventually cause discoloration or vinyl degradation to the bottom of the cover.

Never leave an open spa unattended if children are present!

WARNING: Do not turn off the jet pump prior to the end of the 10-minute "clean-up" cycle if chlorine has been administered to the spa water. If undissolved chlorine remains in the seating or foot well area, it may not only bleach out the color of the spa shell, but may result in paper thin chemical burns (blisters).

Chemical induced surface blistering is classified as abuse and is not covered under warranty. Additionally, there is no spa surface material (fiberglass, gelcoat or acrylic) that will withstand this type of abuse.

CAUTION/WARNING: Watkins Manufacturing Corporation does not recommend the use of any type of floating chemical dispenser.

MINERAL CONTENT

Total Alkalinity & Calcium Hardness

Proper mineral content is also an important factor in spa water. Total Alkalinity (TA) and Calcium Hardness (CH) are the primary minerals of concern. Total alkalinity is a measure of the buffering capacity of water, or its ability to resist a change in pH. Technically, total alkalinity is the total of carbonates, bicarbonates, hydroxides, and other alkaline substances in the water. When total alkalinity is too low, it will cause the pH level to fluctuate widely and can result in corrosive water. When total alkalinity is too high, the pH level will tend to be high (and difficult to lower) and may cause scale to form on the spa surface and equipment.

The recommended Total Alkalinity for your spa water is 125 – 150 ppm.
The Calcium Hardness level should be maintained in the 100 – 200 ppm range.

Low levels of calcium (water too soft) can lead to corrosion of equipment and staining of the spa shell surface. High levels of calcium can cause scaling of equipment and the spa shell surface.

pH CONTROL

Maintaining proper pH is extremely important for sanitizer effectiveness, user comfort, and for preventing equipment deterioration. pH is the measure of acidity and alkalinity in the water. The proper level is 7.4 to 7.6. This level is not only considered safe for spa surfaces and equipment, but is a comfortable level for a spa user's skin.

If a pH is high (above 7.8), chlorine sanitizers are less effective, spa surfaces and equipment can scale, water may become cloudy, and filter cartridge pores may become obstructed. Correct this high pH condition by adjusting with a pH "decrease" additive.

Low pH (below 7.0) causes sanitizers to dissipate more rapidly, increases corrosion of equipment, and may make the water irritating to spa users. Adjust low pH by using a pH "increase" additive.

pH Test: The pH of the spa water should be tested either with a Phenol Red reagent or a test strip and compared to the calibrated color standards on the test block.

pH		
ALKALINE SPA WATER (SCALING ZONE)	8.2 — 7.8	ADD pH DECREASER TO LOWER pH
COMFORT ZONE		
IDEAL		
ACIDIC SPA WATER (CORROSIVE ZONE)	7.6 — 7.4 — 7.2 — 6.8	ADD pH INCREASER TO RAISE pH

The recommended pH for your spa water is 7.4 – 7.6.

pH DO's AND DON'Ts

1. Many swimming pool water care products can cause damage to spa surfaces and equipment of smaller bodies of water such as spas. For this reason:

DO NOT use swimming pool (muriatic) acid to lower pH.

2. Many pH "increase" additives in the carbonate chemical family will cause redwood to turn dark by pulling the tannin (reddish color in redwood) out of the wood. For this reason:

DO NOT splash pH "increase" additives on the redwood skirt during pH adjustment.

DO use care if using baking soda to clean either the interior or the exterior plastic spa surfaces.

IMPORTANT: Spa water additives for pH control should always be added into the filter compartment while the jets are running. Failure to maintain proper pH will result in damage to various components, including the ENDUROL surface, and may void your warranty.

SANITATION Chlorine

There are several forms of stabilized chlorine available for use in spas and swimming pools. Each form has specific chemical characteristics which makes it EXTREMELY IMPORTANT that you use the one specifically designed for small bodies of water such as spas.

WARNING: Using the **incorrect** product such as Trichlor, which has a very low pH (2.6), dissolves very slowly, is highly concentrated, and was designed for concrete or plaster swimming pools—will cause damage to your HOT SPRING Spa!

Watkins Manufacturing Corporation recommends ONLY "Sodium Dichlor" type granulated chlorine be used for sanitizing the water.

The recommended Free Chlorine Residual for your spa water is 3.0 – 5.0 ppm.

Your HOT SPRING Spa water should not be BELOW A MINIMUM level of 2 ppm Free Available Chlorine Residual unless the spa is equipped with a FRESH WATER Ozone Purification System. Then, a test kit or strip reading of 1 ppm–3 ppm Free Available Chlorine Residual is acceptable.

To maintain the minimum level, Sodium Dichlor type granulated chlorine must be added to your spa **daily**. It is also advisable to check the free chlorine residual regularly, especially just prior to use. It is important to note that a spa being used over an extended period of time, such as a whole afternoon or evening, will need chlorine added at least every hour or more frequently to maintain the **minimum** level of 2 ppm Free Chlorine Residual. The recommended **maximum** chlorine level when **using** your spa is 5 ppm or less.

In addition to maintaining your spa's Free Chlorine Residual in the 3 ppm—5 ppm range or 1 ppm—3 ppm range for a spa equipped with an ozone system, a **weekly** "shock treatment" is required. When using a chlorine water sanitation system, the shock treatment is a process in which you add substantial amounts (see Sanitation Table) of Sodium Dichlor to SUPER-CHLORINATE your spa water to a level of 10 ppm. This super-chlorination destroys chloramines and non-filterable organic wastes. After the super-chlorination, allow the chlorine level to drop below 5 ppm before using your spa.

If you use your HOT SPRING Spa daily, the water should be SUPER-CHLORINATED to a level of 10 ppm at least once per week to oxidize chloramines and organic wastes.

Super-chlorination is recommended after refilling your spa each time. This process will kill any bacteria which may be present in the plumbing or may have entered the spa during non-use.

WARNING: Improper chemical maintenance may increase the risk of catching or spreading infection. Also, no one should be in the spa while chemicals are being added or dissolving.

Testing – Free Available Chlorine

To test for Free Available Chlorine using a DPD Test Kit, remove the stopper plug from the test block chamber marked Chlorine or CL, tightly cover the chamber with your finger and dip the test block into the spa water. At approximately 18" below the water, remove your finger and allow the chamber to fill to the top line. Remove the test block and place one DPD#1 tablet in the filled CL chamber. Replace the stopper plug and shake the test block until the tablet is completely dissolved. Make a comparative test of the color in the chamber to the color standards on the test block. This reading will be your Free Chlorine residual level.

To test for Free Available Chlorine using Test Strips, dip the end pad on the strip into the spa water and move back and forth for 30 seconds. Remove the test strip and make a comparative test to the color standards on the bottle.

Super-Chlorination Test

To test for 10 ppm Free Available Chlorine using a test block that is only calibrated to 3.0 or 5.0 ppm, the following procedures should be followed:

FOR A TEST BLOCK CALIBRATED TO 3 PPM

1. In a glass, mix 1 test block full of spa water with 2 full test blocks of DISTILLED WATER.
2. Pour a portion of this water mixture back into the chlorine test block until it reaches the top line. Place one DPD#1 tablet in the chlorine chamber, replace the stopper piug and shake the test block to dissolve the tablet.
3. Match the color of the water sample to the calibrated test block color standards.

4. Multiply the chlorine level indicated by 3. Example: If the color standard indicates a level of 2.5 ppm then the Free Available Chlorine is 7.5 ppm. NOTE: To reach a level of 10 ppm, the water sample's color should be slightly darker than 3 ppm.

FOR A TEST BLOCK CALIBRATED TO 5 PPM

1. In a glass, mix 1 test block full of water with 1 full of DISTILLED WATER.
2. Same steps as 2, 3, and 4 previously stated.
3. Multiply the chlorine level indicated by 2.

SANITATION TABLE

SPA GALLONAGE	200-225 GAL	300-326 GAL	400-425 GAL	500-525 GAL
DAILY CHLORINATION	3/4 TSP	1 TSP	1 1/2 TSP	2 TSP
WEEKLY SUPER-CHLORINATION	2 TSP	3 TSP	4 TSP	5 TSP

RECOMMENDED SANITIZER: Sodium dichloro-s-triazinetriene, granular **or** Sodium dichloroisocyanurate, granular (Common Name: Dichlor Chlorine, granular, 53%-65% available chlorine).

DAILY CHLORINATION: Maintain level of 3-5 ppm free available chlorine residual **or** 1-3 ppm residual for a spa equipped with a FRESH WATER Ozone Purification System. Push in the button labeled "Clean-up Cycle" and add the recommended amount of dichlor **into** the filter compartment while the jet pump is operating. The jet pump will shut off automatically after 10 minutes.

NOTE: A spa with a FRESH WATER Ozone Purification System will require less chlorine than stated in the Sanitation Table to achieve the recommended 1-3 ppm chlorine residual.

WEEKLY SUPER-CHLORINATION: Push in the button labeled "Clean-up Cycle" and add the recommended amount of dichlor **into** the filter compartment while the jet pump is operating to raise the free available chlorine residual **above 10 ppm**. The thermal cover should remain open during a "shock treatment." Once the jet pump has shut off after the 10 minute clean-up cycle, close and secure the thermal cover. Allow the free chlorine residual to drop to 5 ppm or below before using the spa!

HOT SPRING PORTABLE SPA STANDARD CHEMICAL SANITATION PROGRAM

CHLORINE DPD TEST KIT READING	DO NOT USE THE SPA UNTIL THE TEST KIT READING IS BELOW THIS LEVEL
5.0	RECOMMENDED LEVEL SAFE
4.0	
3.0	
ADD CHLORINE	
2.0	DO NOT USE SPA; ADD CHLORINE TO REACH RECOMMENDED SAFE LEVEL
1.0	
0	

DO's AND DON'Ts OF SPA WATER MAINTENANCE

- Many sanitizers, though of the same chemical family, have differing rates of solubility and pH. Their effectiveness could either be substandard or exceptionally harsh and damaging to the spa surface and equipment. For this reason:
DO NOT use "Tri-Chloro" granulated or tablet chlorine.
DO use Sodium Dichlor type granulated chlorine.
- Your HOT SPRING Spa dealer may recommend a BROMINE spa water sanitation program. Whereas bromine and bromamines (the combined form of bromine) are effective sanitizers, the methods in which it is administered to the spa water and the quality and composition of the product varies from each chemical manufacturer. The use of bromine sticks or tablets in floaters which may become entrapped on a lounge or cooling seat (or sink to the spa floor) have shown to cause discoloration or surface distress to the PVC and ABS spa fittings. (The ENDUROL spa shell can withstand the effects of Bromine except in instances where a floating dispenser becomes entrapped or if the dispenser is set on too high of a setting, thus creating an "over-bromination" or "high concentration" situation. In these situations, discoloration to the spa shell may occur.) In addition, automatic floating dispensers either have a tendency to "over" brominate or "under" brominate as the rate of erosion varies greatly and must be monitored. For these reasons, we strongly recommend:

DO NOT use a bromine sanitation system as a low or no maintenance solution to your spa water sanitation program. If a bromine sanitation system is used, Quick-Dissolving Granulated Bromine is recommended. If a bromine sanitation system utilizing a floating dispenser is used (this method is **NOT** recommended by Watkins Manufacturing), carefully follow your authorized dealer's written instructions and discontinue its use immediately should signs of discoloration to the spa shell surface occur.

- Many sanitizers may raise the level of total dissolved solids in water or are dangerous to handle. For this reason:
DO NOT use household bleach (liquid sodium hypochlorite).
- The instructions for use on many spa product labels recommend casting or sprinkling the chemicals onto the water surface. This method may cause chemically induced spa surface blistering (chemical abuse). For this reason:
DO NOT add chemicals directly onto the water surface.
DO add all chemicals slowly into the filter compartment.
- DO NOT** store chemicals in the spa's equipment compartment.

IMPORTANT: Granulated chlorine will degrade if stored improperly or for a long period of time. We recommend purchasing granulated Dichlor in one or two pound containers and storing it in a cool place to maintain the chlorine's freshness. Use care when handling.

WATER PURIFICATION – OZONE GENERAL INFORMATION

Two types of ozone purification systems are approved for installation in your HOT SPRING Spa. The first type is an externally mounted unit called FRESH WATER I, which utilizes an ultraviolet (U.V.) lamp to produce the required amount of ozone. The second type is called FRESH WATER II, which utilizes corona discharge (C.D.) technology to produce a higher level of ozone than can be achieved by an ultraviolet light system. This higher output is necessary as FRESH WATER II is installed under the spa skirt (in the equipment compartment) where the effects of higher humidity and warmer temperatures will slightly reduce its efficiency. Because a C.D. unit produces a higher level of ozone than a U.V. unit, it is able to compensate for the degrading effects within the equipment compartment. The result is that it will still produce the level of ozone that meets our minimum standard of at least 250 ppm ozone in air in order to achieve the highest level of contamination oxidation.

Each type of high output ozone unit manufactured by Watkins offers its own advantages. The externally mounted FRESH WATER I unit is easily accessible for periodically checking the flow indicator or lamp operation. The under-the-skirt mounted FRESH WATER II unit offers the less visible installation and is less susceptible to the effects of freezing temperatures but is not easily accessible for inspection. The door to the equipment compartment will need to be removed to check ozonator operation (this is usually done prior to disconnecting power to the spa prior to draining.)

The WATKINS FRESH WATER High Output Ozone Purification Systems are designed to greatly enhance the quality of the spa water when used to supplement the spa owner's regular water maintenance program. Contrary to some information circulated throughout the pool and spa industry regarding ozone systems, there is limited third party data available to support claims that ozone can be used as a single-source sanitizer, water clarifier, anti-foamer, and mineral chelating agent. Watkins Manufacturing Corporation recommends that a chemical maintenance program based on recognized and documented industry standards still be followed when using an ozone purification system to assure water sanitation and the highest quality purified water is achieved.

HOT SPRING PORTABLE SPA EQUIPPED WITH A FRESH WATER OZONE PURIFICATION SYSTEM

CHLORINE DPD TEST KIT READING	DO NOT USE THE SPA UNTIL THE TEST KIT READING IS BELOW THIS LEVEL
5.0	SAFE
4.0	
3.0	
2.0	RECOMMENDED LEVEL WITH OZONE SYSTEM SAFE
1.0	DO NOT USE SPA; ADD CHLORINE TO REACH RECOMMENDED SAFE LEVEL
0	

Questions and Answers regarding the FRESH WATER Ozone Purification System:

1. What is ozone?

Ozone is a powerful oxidizing agent which is produced in nature or artificially by man. In nature, ozone is produced in the lower atmosphere to purify the air we breathe. In the upper atmosphere, ozone is produced by the sun's U.V. light, forming a shield

around the earth which filters out some of the sun's harmful rays.

2. How does ozone purify?

The FRESH WATER Ozone Purification System produces ozone at your spa site to "burn out" water contaminants, bacteria and viruses through the process of oxidation.

3. What is the design concept for either of the FRESH WATER Ozone Purification Systems?

The purification systems have been specifically designed to operate on all 1995 model HOT SPRING and TIGER RIVER Spas manufactured with the 24-hour continuous filtration system. Each system utilizes a high output generator that draws ambient air into an encapsulated reaction chamber to consistently produce the highest level of ozone. To ensure that the ozone is transferred to the spa water efficiently (and will not cause damage to any spa components), FRESH WATER I and II utilize a special ozone resistant injection system that includes a Kynar injector and delivery tubing. This ozone delivery system was designed on the hydraulics of the spa's continuous circulation system and so as a result, works with the spa's filtration system to achieve the highest level of water clarity.

4. How do the FRESH WATER Systems work?

FRESH WATER I and II both rely on the ozone injector to create a venturi effect that draws ambient air into the generator's reaction chamber. The frequency of light from the U.V. lamp in the FRESH WATER I unit or the electrical discharge occurring within the tube in the FRESH WATER II unit, converts oxygen (O₂) contained in the air to ozone (O₃). This ozone enriched air is then drawn to the throat of the injector. At the injector, hundreds of small ozone bubbles are produced every minute and injected into the water stream. Because of their smaller size, the ozone gas is easily absorbed into the spa water where it immediately begins oxidizing all contaminants. To ensure that the ozone gas bubbles have an adequate amount of contact time in which to complete the oxidation process, all 1995 HOT SPRING Spa models are equipped with a ten foot contact chamber. As a result of the efficiency of the reaction chamber within the ozone generator, the delivery system and the contact chamber, a minimum of off-gassing occurs. (Off-gassing is defined as the amount of active ozone that reaches the spa water surface prior to converting back to oxygen because of inefficient absorption.)

5. Why is ozone used for spa water treatment?

Ozone has five major benefits or advantages that make it ideal for water treatment:

1. Ozone is the most powerful oxidizing agent commercially available, outperforming chlorine and bromine. (But, ozone does not maintain a residual and as a result a sanitizer residual is required.)
2. Ozone is the most effective viral disinfectant commonly available for water treatment.
3. Ozone forms no harmful by-products such as chloramines.
4. Ozone will not alter the water's pH.
5. Ozone reduces the average chemical usage a minimum of 50%.

WARRANTY INFORMATION: As per the terms of the limited warranty of HOT SPRING Spas, any component or unit failure resulting from the installation of any non-approved sanitation or water purification system device will void the spa's warranty.

For additional information of either FRESH WATER I or II Ozone Purification Systems, please contact your authorized HOT SPRING Spa dealer.

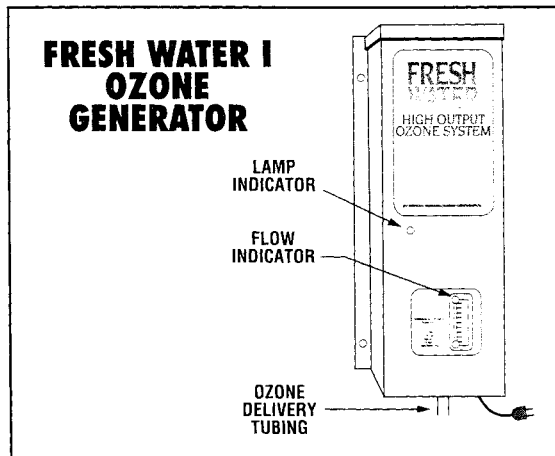

SUPPLEMENTAL WATER MAINTENANCE

Proper water sanitation and mineral balance (pH control) are ABSOLUTELY essential for a spa water maintenance program. The following four points are optional:

Flocculating Agent

A flocculating agent consists of relatively large particles which when added to water attract very small particles to them like a magnet. These small particles will normally

go through some cartridge filters. When they are attached to the flocculent particles, however, the combination is large enough to be trapped. The flocculent allows clarification of water contaminated with particles too small for some filters. Water sanitation is not improved by flocculating agents because with proper chlorination these small particles are rendered inert (biologically dead).

Water Color Control

Water color in a shallow body of water such as a spa assumes the color of the spa. This can be seen in a swimming pool where the deep end seems to be tinted blue while the shallow end appears white. Some spa products have a blue appearance and will impart a blue color to the spa water.

Soap Foam Inhibitor

The main reason water change is necessary in a hydrotherapy spa is soap build-up in the water. The soap comes from users' bodies, which retain soap residual after showering, and also from swimming apparel, which retains soap after washing. Foam inhibitors will suppress foam but cannot remove soap from water. The soap is not oxidized by any chemical (except by ozone). Eventually the soap build-up in the water will be concentrated enough to leave an unclean feeling on the skin and make the water impossible to clarify. Depending on the soap input, the spa water should last between two and three months.

Mineral Deposit Inhibitors

As water evaporates from your spa, and make-up water is added, the amount of dissolved minerals that the spa water contains increases. The spa water will eventually become "hard" enough to damage the heater by calcifying the surface. Proper pH control can minimize this. Normal soap build-up demands water replacement regularly enough to where mineral depositing usually is not a problem. Keeping a lid on the spa will reduce evaporation substantially, and delay the water's hardening. Occasionally, high copper content or high iron content in the water may produce green or brown stains on the spa. In these cases, a mineral deposit inhibitor may be of help.

SERVICE NOTE: Well water may contain high concentrations of minerals. The use of a low water volume, extra fine pore water filter will help to remove many of the larger particles during the filling of the spa. These in-line, prefilters can usually be purchased at a hardware or plumbing supply store.

IMPORTANT: Contact your local HOT SPRING Spa dealer if you have a specific water chemistry problem or require assistance in developing a "spa care" program.

SPA WATER MAINTENANCE Troubleshooting Guide

PROBLEM	PROBABLE CAUSE	SOLUTIONS
<i>Cloudy Water</i>	<ul style="list-style-type: none"> • Inadequate filtration/dirty filter • Excessive oils/organic matter • Improper sanitation • High pH and/or high alkalinity • Suspended particles/organic matter • Overused or old water 	<ul style="list-style-type: none"> • Clean filters with a filter cleaner or degreaser. • Shock the spa with chlorine (super-chlorinate). • Increase sanitizer to recommended level. • Adjust pH; add appropriate sodium bisulfate product. • Use clarifier. • Drain the spa, clean and refill.
<i>Water Odor</i>	<ul style="list-style-type: none"> • Excessive organics/ too many chloramines –insufficient free available chlorine • Improper sanitation • Low pH 	<ul style="list-style-type: none"> • Shock the spa with chlorine. • Increase sanitizer level to recommended level. • Raise pH with sodium bicarbonate product.
<i>Chlorine Odor</i>	<ul style="list-style-type: none"> • Too many chloramines–insufficient free available chlorine • Low pH 	<ul style="list-style-type: none"> • Shock the spa with chlorine. • Adjust pH; raise pH with sodium bicarbonate product.
<i>Musty Odor</i>	<ul style="list-style-type: none"> • Bacterial or algae growth 	<ul style="list-style-type: none"> • Shock the spa with chlorine. If problem visible, draining and cleaning may be required.
<i>Foaming</i>	<ul style="list-style-type: none"> • Buildup of body oils, lotion and chemicals resulting in soap or detergent • Overused or old water • Excessive organics 	<ul style="list-style-type: none"> • Add defoamer; or drain and refill. • Drain and refill. • Shock with chlorine.
<i>Organic Buildup/Scum Ring Around The Tub</i>	<ul style="list-style-type: none"> • Body oils and dirt 	<ul style="list-style-type: none"> • Wipe off scum with a clean rag. Depending on severity–drain spa, use a spa surface and tile cleaner to remove the scum, refill spa and adjust water.
<i>Algae</i>	<ul style="list-style-type: none"> • Inadequate filtration • High pH • Low free chlorine 	<ul style="list-style-type: none"> • Clean filter with a filter cleaner or degreaser. • Shock with chlorine; adjust pH. • Shock with chlorine; maintain sanitizer at recommended level.
<i>Eye Irritation</i>	<ul style="list-style-type: none"> • Low pH • Insufficient free available chlorine 	<ul style="list-style-type: none"> • Raise pH with sodium bicarbonate product. • Shock with chlorine.
<i>Skin Irritation/Rash</i>	<ul style="list-style-type: none"> • Unsanitary/polluted water • Chlorine level too high (above 5ppm FAC). 	<ul style="list-style-type: none"> • Maintain recommended sanitizer residual at all times; super-chlorinate. • Allow chlorine level to drop below 5ppm before using spa.
<i>Stains</i>	<ul style="list-style-type: none"> • pH or total alkalinity too low • High iron or copper in water source 	<ul style="list-style-type: none"> • Adjust pH and total alkalinity; use sequestering agent; drain and clean with appropriate product. • Use sequestering agent for metals; adjust water.
<i>Scale</i>	<ul style="list-style-type: none"> • Too much calcium dissolved in water–pH and total alkalinity too high 	<ul style="list-style-type: none"> • Adjust total alkalinity and pH levels by adding the appropriate sodium bisulfate product; with concentrated scale deposits–drain the spa, scrub the scale off, refill the spa and balance the water.

VII. SERVICE INFORMATION

GENERAL INFORMATION

The HOT SPRING Spa has been designed to provide years of trouble-free use. As with any appliance, problems may occasionally occur that require the expertise of a qualified service person. Though such simple repairs as resetting a G.F.C.I. switch or breaker, resetting a high limit thermostat or replacing a light bulb may not require a service call, they may indicate a more serious condition exists. These conditions may require an experienced service person. Before calling for service, please refer to the TROUBLESHOOTING GUIDE.

NOTE: Always retain your original sales receipt for future reference.

G.F.C.I. AND HIGH LIMIT THERMOSTAT

If your spa fails to operate at any time, the following items should be checked:

1. Check the power supply to the spa.
2. On the 115 Volt CLASSIC, SOVEREIGN, PRODIGY and JETSETTER spa models, check the G.F.C.I. at the end of the power cord. On the 230 Volt GRANDEE, HIGHLIFE, CLASSIC (FH) and SOVEREIGN (IH) models, check each of the G.F.C.I. breakers in the subpanel. If a G.F.C.I. has tripped, reset it. If it will not reset, this may be an indication of a ground fault (short circuit) within the electrical components. Contact an authorized service technician for a complete diagnosis.
3. If upon checking the G.F.C.I.s you find that they have not tripped, check the house breaker panel and ensure the main breaker for the electrical circuit supplying the spa has not tripped. If it has, this is an indication that the circuit was either overloaded or a ground fault exists between the breaker panel and the spa receptacle or subpanel. Contact a qualified electrician.
4. If upon checking the main house breaker and spa G.F.C.I.s you find no failures, the high-limit thermostat should be checked. To check it, simply turn off power to the spa for 30 seconds (trip the G.F.C.I. breakers). This will automatically reset the high-limit thermostat if it had tripped. If the spa energizes once you turn the power back on, then there is an indication of reduced water flow through the heating system. Tripping of the high-limit thermostat is normally a result of one or a combination of any of these problems. 1) clogged filter cartridge, 2) blockage within the system plumbing, 3) a non-functioning heater circulation pump, 4) power was not disconnected from the spa

before it was drained,

- 5) an air lock in the plumbing lines. (The Power-On Indicator on the front of the spa's control panel will also be blinking if the high-limit thermostat has tripped.)
5. If the spa does not function and upon tripping and resetting the G.F.C.I.s (step # 3 above) or resetting the high-limit thermostat (step # 4), then the problem should be referred to a qualified service technician. Refer to the Heater, Flow Switch Controller section if the spa operates but does not heat, or refer to the Troubleshooting Guide for additional service information.

"NO FAULT" HEATER AND FLOW SWITCH CONTROLLER

The new Watkins "No Fault" cartridge heater is called the "No Fault" heater because it comes with an unconditional warranty (vs. the normal "limited" warranty). This means that any failure during the stated warranty period that requires the replacement of the cartridge heater or its hybrid polymer housing will be warranted unconditionally.

It is important to note that the HOT SPRING heater is protected by both the heater high-limit thermostat and the flow switch controller. The causes of heater high-limit tripping are discussed in the previous section.

If the tub is not heating (but the pump and light operate), then the flow switch controller should be checked. To check it, simply turn off power to the tub for 30 seconds (trip the G.F.C.I.). This will automatically reset the flow switch if it had tripped. If the tub heater energizes once you turn the power back on, then this is an indication of reduced water flow through the heating system. Tripping of the switch is normally a result of one or a combination of these problems: 1) a clogged filter cartridge, 2) blockage within the system plumbing, 3) power was not disconnected to the tub before it was drained, or 4) an air lock in the plumbing lines. Once the problem has been identified and corrected the flow switch will be able to be reset which will energize the tub heater.

FRESH WATER SYSTEM

The FRESH WATER Ozone Purification Systems are low-maintenance electrical devices. A blue glow from the lamp indicator located on the front face of the FRESH WATER I ozone generator will indicate that the U.V. lamp is functional. The unit is also equipped with a flow meter which indicates ozone is flowing to the spa at the recommended rate. If the meter reads low, then either the filter cartridge is in need of cleaning or there may be condensation in the delivery tubing. With either FRESH WATER system, the appearance of bubbles entering the spa water at the heater return indicates air flow through the system. The faint sweet fragrance of ozone will also accompany the bubbles (the fragrance will be most noticeable when the spa cover is opened).

spa water at the heater return indicates air flow through the system. The faint sweet fragrance of ozone will also accompany the bubbles (the fragrance will be most noticeable when the spa cover is opened).

On the FRESH WATER I unit, if the blue indicator is not illuminated then either A) the U.V. lamp is burned out, or B) the lamp ballast is nonfunctional as a result of equipment failure or low temperature. (The ballast has a temperature rating of 5 degrees F. If power was disconnected to the system when the ambient temperature was below 5 degrees F, then no malfunction exists. The system will operate once the ambient temperature has risen above 5 degrees F). As long as the FRESH WATER I unit is connected to a power source, the flow of warm ozone gas from the generator will usually prevent condensation or ice from forming in the delivery tubing except during rapid ambient temperature changes. Condensation that may accumulate will eventually evaporate as temperatures stabilize. Freezing of the delivery tubing (as indicated by no flow through the meter), will require thawing before ozone flow can resume. Always maintain a clean filter cartridge (to increase the water circulation rate and venturi effect on the ozone delivery tubing) during extreme subfreezing temperatures.

A FRESH WATER II system is practically maintenance free because it is located within the spa's equipment compartment. If bubbles are appearing at the spa's heater return but the smell of ozone is not noticeable (the water may also not appear as clear as usual) then the operation of the generator should be checked. Carefully open the equipment compartment door (remember use care as power is still connected to the spa) and verify the C.D. tube and its transformer are energized. (A slight buzz will be emitted from the ozone generator housing.) If a slight buzz or hum is not audible, verify the generator is completely plugged into the spa's control box.

If the unit is plugged in and power is connected to the spa, then the fuse (for the generator) should be checked. (See the Owner's Instructions included with the FRESH WATER II Ozone Purification System for further information on service.)

WARNING: Watkins Manufacturing recommends contacting your HOT SPRING Spa dealer in the event component replacement or system evaluation is required. FRESH WATER systems should only be serviced by a trained technician.

MISCELLANEOUS SERVICE INFORMATION

The control and high limit thermostats are equipped with electronic sensors that are connected to the spa's plumbing. Never cut or kink the wires that connect the sensors to the thermostats within the control box.

The jet pump is equipped with a thermal overload cutoff switch which is designed to protect the pump from overheating. If the pump shuts itself off in an older spa, it could indicate failure of the pump motor bearings. If the

pump shuts itself off in a new spa, it is usually the result of one, or a combination of the following factors:

Thermal Overload: Although mass-produced, not all thermal overload cutoffs are exactly the same. Some are more sensitive than others and will shut the pump off at lower temperatures.

High Temperature: All HOT SPRING Spa models are equipped with a jet pump shroud which allows the heat generated by the pump motor to be vented from the equipment compartment. If the vent is blocked by masonry, grass or debris, overheating of the jet pump may occur. Once the pump motor has cooled sufficiently and any blockage removed from the vent opening, the jet pump can be restarted.

Friction: Sometimes the moving parts of a new pump are tight enough to cause heat build-up due to friction. After a normal break-in period, the pump will run cooler.

Improper Wiring: If the spa is connected to an extension cord, and/or the house wiring is undersized, the pump may starve for voltage and therefore draw more amperage and generate excessive heat.

If the pump is shutting down due to excessive heat, make sure the equipment compartment has adequate ventilation. The air gap at the bottom must not be blocked. Should your jet pump continue to shut off after short periods of use, contact a qualified service technician.

ACTS INVALIDATING WARRANTY

The warranty is void if the HOT SPRING Spa has been subjected to alteration, misuse or abuse, or if any repairs on the spa are attempted by anyone other than an authorized representative of Watkins Manufacturing Corporation. Alteration is defined as any component or plumbing change, electrical conversion, or the addition of any non-approved sanitation or water purification device or heating system which contributes to a component failure, unit failure or unsafe operating condition. Misuse and abuse shall include, any operation of the spa other than in accordance with Watkins Manufacturing Corporation printed instructions or use of the spa in an application for which it is not designed. Specifically: use of the spa in a non-residential application, damage caused by operation of the spa at water temperatures outside the range of 32 degrees F and 120 degrees F, damage caused by dirty, clogged or calcified filter cartridges; damage to the spa surface caused by the use of Tri-Chloro chlorine, chemical tablets, acid, or any other spa sanitizing chemicals or spa surface cleaners which are not recommended by Watkins Manufacturing Corporation; damage caused by allowing undissolved spa sanitizing chemicals to lie on the spa surface (no spa surface material can withstand this kind of abuse); damage to components or spa surface caused by improper pH balance or other improper water chemistry maintenance; and damage to the spa surface caused by

DISCLAIMERS

Watkins Manufacturing Corporation shall not be liable for loss of use of the HOT SPRING Spa or other incidental or consequential costs, expenses or damages, which may include but are not limited to, the removal of a permanent deck or other custom fixture. Any implied warranty shall have a duration equal to the duration of the applicable warranty stated above. Under no circumstances shall Watkins Manufacturing Corporation or any of its representatives be held liable for injury to any person or damage to any property, however arising.

WATKINS CUSTOMER SERVICE

If you have any questions about any aspect of your HOT SPRING's setup, operation or maintenance, that have not been answered by your HOT SPRING dealer, Watkins Manufacturing Corporation's Customer Service Department can be reached toll-free at
800-999-4688 (Extension 432).

TROUBLESHOOTING GUIDE

SYMPTOM	PROBABLE CAUSES	SOLUTIONS
Entire spa inoperative.	<ul style="list-style-type: none"> • Power failure outside of spa. • G.F.C.I. tripped. • HEATER high limit thermostat tripped. (Power-on indicator flashing) 	<ul style="list-style-type: none"> • Check power source. • Reset G.F.C.I.; call for service if it will not reset. • Check for clogged filter cartridges (clean if necessary). Trip (wait 30 seconds) then reset G.F.C.I. to reset high-limit thermostat. If it will not stay reset and no plumbing restrictions are located, the circulation pump has failed. Call for service.
Spa does not heat; jets and light operate.	<ul style="list-style-type: none"> • Flow switch controller tripped. 	<ul style="list-style-type: none"> • Check for clogged filter cartridge (clean if necessary). Flow switch will automatically reset with increased water flow. Call for service if it happens frequently.
Jets weak or surging.	<ul style="list-style-type: none"> • Spa water level too low. • Dirty or clogged filter cartridges. • Air control valves closed or restricted. 	<ul style="list-style-type: none"> • Add water. • Clean or replace filter cartridges. • Open air control valve.
Light inoperative.	<ul style="list-style-type: none"> • Burned out bulb. 	<ul style="list-style-type: none"> • Replace bulb.
MOTO-MASSAGE JET inoperative or erratic.	<ul style="list-style-type: none"> • Air control valves closed or restricted. • Filters clogged or restricted. • MOTO-MASSAGE JET nozzle air line has pulled away from fitting. 	<ul style="list-style-type: none"> • Open air control valve. • Clean or replace filter cartridges. • Remove MOTO-MASSAGE JET face plate and push on air line. Refer to instructions, page 20.
Power-on Indicator is blinking. (Entire spa inoperative.)	<ul style="list-style-type: none"> • HEATER high limit thermostat tripped. 	<ul style="list-style-type: none"> • Check for clogged filter cartridges (clean if necessary). Reset high-limit thermostat. Call for service if it happens frequently.

IMPORTANT: Refer to the spa and equipment drawings in the Spa Specification Section to locate the component or control identified in this Troubleshooting Guide.

WatkinsTM

The Home Relaxation Specialists

WATKINS MANUFACTURING CORPORATION
VISTA, CALIFORNIA
U.S.A.



This manual contains installation, operating, maintenance and service information for the following HOT SPRING SPA models:



<u>U.S.A. MODELS</u>	<u>EFFECTIVE DATE</u>	<u>CANADIAN MODELS</u>	<u>EFFECTIVE DATE</u>
GRANDEE® (Model G)	1/96	GRANDEE® (Model GC)	1/96
HIGHLIFE® (Model K)	1/96	HIGHLIFE® (Model KC)	1/96
CLASSIC® (Models F & FH)	1/96	CLASSIC® (Models FHC)	1/96
SOVEREIGN® (Models I & H)	1/96	SOVEREIGN® (Models IHC)	1/96
PRODIGY® (Model H)	1/96	PRODIGY® (Model HC)	1/96
JETSETTER® (Model J)	1/96	JETSETTER® (Model JC)	1/96